

The screenshot displays the Eaton Intelligent Power Protector web interface. The main content area is titled "Power Source" and shows the configuration for a device with IP address 166.99.224.119. The interface is divided into several sections:

- Information and Status:** Displays device details such as Description (Evolution 650), Nominal apparent power (650 VA), IP address (166.99.224.119), Mac Address (00:20:85:FD:76:08), Serial number (AV0J1901H), Class (Network Management Card / HA), Location (1A09), Contact (Luc), and Link.
- Battery state:** Shows the device is charging and on utility. Battery level is at 29% (29% of capacity), and battery capacity is at 100%. Battery run time is 12 min 05 s. Master output and two load segments are all "On".
- Measures:** A table of real-time measurements:

Input frequency	50 Hz
Input voltage	233 V
Output frequency	50 Hz
Output voltage	233 V
Output current	0 A
Global apparent power	161 VA
Global active power	121 W
Battery output voltage	13 V
- Environment:** A section for environmental data, currently empty.
- Synoptic:** A schematic diagram of a Line Interactive UPS with outputs for Master output, Load segment #1, and Load segment #2.
- Graph - 2 hours:** A line graph showing power and battery status over a 2-hour period from 06/03/10 - 7:49:16 am to 06/03/10 - 9:49:16 am.
- Statistics - 7 days:** A section for 7-day performance statistics, currently empty.
- Events:** A section for recent events, currently empty.

The bottom status bar shows system health: OK: 13, Warning: 2, Critical: 4, Unknown: 12. The last event is dated 05/31/10 - 8:05:43 am - 166.99.224.43 - End of UPS shutdown imminent alarm.

Table of Contents

1	Introduction	4
2	Installation	5
2.1	Installation Prerequisites	5
2.1.1	On the System Hosting « Intelligent Power® Protector »	5
2.1.2	On the System that Displays Web-based Graphical User Interface	6
2.2	Quick Start & Installation	7
2.3	Windows Installation	9
2.3.1	Graphical installation	9
2.3.2	Silent installation	9
2.3.3	Installation Result	10
2.3.4	Uninstalling the Product	10
2.4	Linux Installation	11
2.4.1	Native installation on a RedHat, SuSe, Mandriva or derivative system:	11
2.4.2	Native installation on a Debian or derivative system:	12
2.4.3	Generic installation on Linux	13
2.4.4	Uninstalling the Product	14
3	Configuration	15
3.1	Intelligent Power® Protector Settings	15
3.1.1	Discover the UPSs connected through USB/Serial	15
3.1.2	Discover the nodes Connected on the Network	16
3.1.3	Shutdown	18
3.1.4	Shutdown Use case	22
3.1.5	Configure Actions	27
3.1.6	Configure User Accounts	34
3.1.7	System settings	35
3.1.8	Shutdown Controller	36
4	Supervision	39
4.1	Access to the monitoring interface	39
4.1.1	Local access	39
4.1.2	Remote access	39
4.1.3	Power Source View	40
4.2	Panels list:	41
4.2.1	Information and status	41
4.2.2	Measures	42
4.2.3	Environment	42
4.2.4	Graph	42
4.2.5	Synoptic	43
4.2.6	Events	45
4.2.7	Statistics	45
4.3	Events	47
4.3.1	List representation	47
4.3.2	Calendar representation	48
4.3.3	Nodes Events list	48
4.4	Launching Device Web interface	50
5	Advanced Management	51
6	Compatibility List	52
6.1	Eaton Serial line Devices	52
6.2	Eaton Network Devices	52
6.3	Eaton Legacy cards	53
7	FAQ and Error messages	54
8	Glossary	57
9	Acknowledgements	58

1 Introduction

The new Eaton graceful shutdown application is called "Intelligent Power[®] Protector"

Intelligent Power[®] Protector:

- Provides **local computer graceful shutdown**
 - acquisition through Eaton UPSs USB or RS232 communication ports (Pulsar & Powerware series)
 - acquisition through Web/SNMP Cards (Network Management Card NMC P/N 66102, Connect UPS MS P/N 103 006 826, Connect UPS XSlot, PXGX 2000 P/N 103005868-5591, ... (*))

(*) Please refer to the "Compatibility list" Chapter for a comprehensive list of the supported cards
- **Can be supervised** by Intelligent Power[®] Manager.
- **Can be managed** by Intelligent Power[®] Manager (mass configuration / mass update/ ...)

2 Installation

2.1 Installation Prerequisites

2.1.1 On the System Hosting « Intelligent Power® Protector »

2.1.1.1 Supported Operating Systems:

Intelligent Power® Protector can be installed on following systems:

- **Windows (x86 & x86_64)** **7 / 2008 / Vista / 2003 / XP**
- **Windows (x86 only)** **2000**

- **Linux (x86/x86_64)**
 - Debian GNU Linux:** **Lenny**
 - SUSE/Novell:** **SLES 11, OpenSUSE 11.2,**
 - RedHat Enterprise Linux:** **RHEL 5.3, 5.4, 5.5, Fedora core 12**
 - Ubuntu:** **10.04**

Virtual Environments:

- **VMware:** **ESX 4, ESXi 4 (pay version only), ESXi 4.10 (pay version only)**
- **Hyper-V:** **Hyper-V and Hyper V Server**

For the installation in these specific “Virtual Environments”, please refer to the user manual appendix that describes the specific steps for those environments.

The Linux package is based on standard Linux mechanisms and therefore can be installed and used with other Linux distributions. Feedbacks / test or bug reports are welcome at EATON Support email address: (contacttechnical at eaton.com).

The following list is not exhaustive. Intelligent Power Protector **should be** compatible with:

- **Linux (x86/x86_64)**
 - Debian GNU Linux:** **Etch, Testing**
 - SUSE/Novell:** **SLES 10, OpenSUSE 10.3**
 - RedHat Enterprise Linux:** **Fedora core 10, 11, 13**
 - Ubuntu:** **8.04, 8.10, 9.04, 9.10, 10.10**
 - Mandriva:** **2010**

2.1.1.2 Software compatibility limitations:

To avoid network or serial port access conflicts, you can not install the Intelligent Power Protector on a machine that also hosts:

- the Eaton Intelligent Power Manager (or Eaton Enterprise Power Manager)
- the Eaton Network Shutdown Module
- the Network Management Proxy
- Personal Solution Pac
- LanSafe and LanSafe Web View
- Netwatch

2.1.1.3 Standby configuration (Windows):

In Configuration Panel -> Power Option properties:

- You must unselect the Standby configuration of your Operating System to be compliant with the Intelligent Power Protector. With the standby configuration checked your system is not protected.
- If you want to save energy, please prefer the hibernate feature.

2.1.1.4 Driver installation

IPP installs all the necessary drivers (USB or serial). If Windows Operating System wants to install a driver from "Windows Update", you can cancel this process.

2.1.2 On the System that Displays Web-based Graphical User Interface

The Eaton Intelligent Power[®] Protector graphical interface can be accessed remotely using a simple Web browser. Access to this interface can be secured through SSL connection and is also secured through Login & password.

The Intelligent Power[®] Protector graphical interface has been tested with:

- Google Chrome 4&5
- Mozilla Firefox 3.0, 3.5, 3.6
- Iceweasel
- Microsoft Internet Explorer V6 & 7, 8, 9 beta
- Opera 10

For optimal performance, Google Chrome or Firefox 3.6 is recommended.

For good performance, Firefox 3.0 or Internet Explorer 7, 8 are possible.

2.2 Quick Start & Installation

To start in 5 minutes, please perform the following steps:

Step 1 (Installation)

On a Windows 2000/XP/2003/Vista/2008/7, Linux, machine, run the “Intelligent Power® Protector” package under an administrator account.



A Web browser is automatically displayed (enter **admin** as Login / **admin** as Password and click on the **Login** button). A popup message advises you to change your default login / password.

What is Eaton Intelligent Power Protector?

- Intelligent Power Protector is protection software offered from Eaton Corporation at 'no charge'. It enables users to avoid data loss by gracefully shutting down computers and servers powered by an Eaton UPS in the event of an extended power outage. This software provides a clear, easy-to-use, multilingual interface from any PC with an Internet browser.
- Exceptionally versatile, Intelligent Power Protector acquires UPS information through local or network communication and can be easily deployed on many computers.
- Intelligent Power Protector can be remotely managed, configured and updated with our Intelligent Power Manager supervisory software. Intelligent Power Manager can be downloaded for no charge from Eaton for supervising / monitoring of a network of up to ten devices. Versions of Intelligent Power Manager for supervising / monitoring many devices may be purchased through an Eaton authorized reseller.

Step 2 (Configuration)

When started, the application automatically performs a **Quick scan**.

- *Using the Quick scan operation, you will discover:*

=> Serial line connected UPSs (RS232 or USB)

The discovered UPS connected through (RS232 or USB) is automatically assigned as the Power source (the Status icon is Green )

=> Networked UPSs through broadcast within a few seconds

Quick Scan is compatible with following Web/SNMP Cards (NMC P/N 66102, Connect UPS MS P/N 103 006 826, Connect UPS XSlot, PXGX 2000 P/N 103005868-5591)

The discovered UPS connected through (Network) are not automatically assigned as the Power source (You have to select the node and click on the button **Set as Power Source** the icon becomes Green )

The discovered nodes are displayed in **Settings → Auto Discovery**

For the other nodes, please perform the discovery based on IP address ranges (**Range scan**)

- Using the *Range Scan operation* you will discover the nodes that are outside of the Network segment







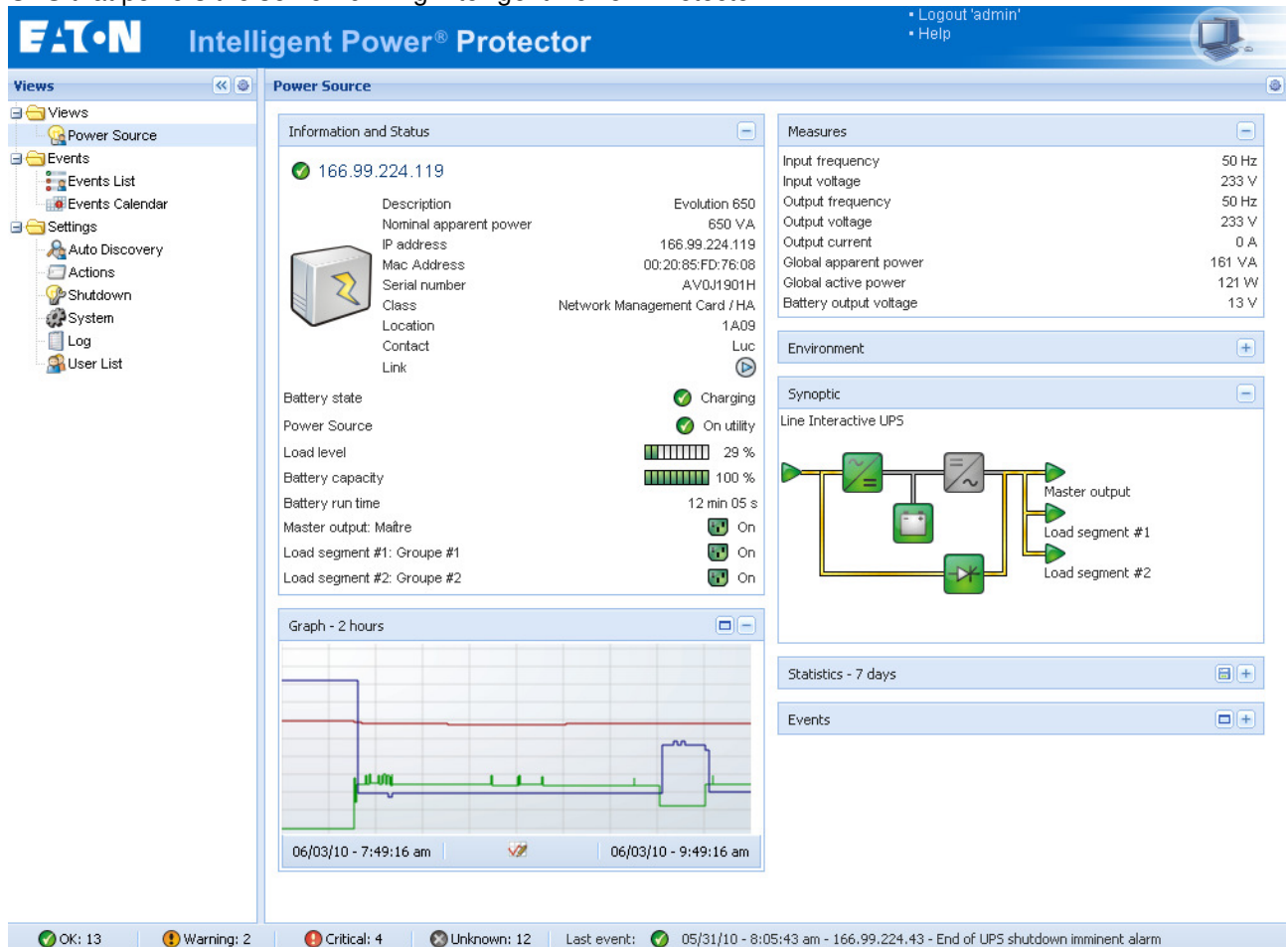

In the **Settings → Shutdown** page, assign the IP address of the UPS that powers the local Computer. In the **Settings → User List** page, assign the access rights through “login and password”

Step 3 (Operation)

The **Views → Power Source** menu item (optional) allows you to supervise the current state of the UPS that powers the server running Intelligent Power® Protector



The screenshot displays the 'Power Source' configuration page in the Eaton Intelligent Power Protector web interface. The interface includes a navigation tree on the left with options like 'Views', 'Events', 'Settings', 'Auto Discovery', 'Actions', 'Shutdown', 'System', 'Log', and 'User List'. The main content area is titled 'Power Source' and shows the following information:

- Information and Status:**
 - IP address: 166.99.224.119 (with a green checkmark icon)
 - Description: Evolution 650
 - Nominal apparent power: 650 VA
 - IP address: 166.99.224.119
 - Mac Address: 00:20:85:FD:76:08
 - Serial number: AV0J1901H
 - Class: Network Management Card / HA
 - Location: 1A09
 - Contact: LUC
 - Link: 
- Battery state:**
 - Charging:  Charging
 - Power Source:  On utility
 - Load level:  29%
 - Battery capacity:  100%
 - Battery run time: 12 min 05 s
 - Master output: Maître  On
 - Load segment #1: Groupe #1  On
 - Load segment #2: Groupe #2  On
- Measures:**
 - Input frequency: 50 Hz
 - Input voltage: 233 V
 - Output frequency: 50 Hz
 - Output voltage: 233 V
 - Output current: 0 A
 - Global apparent power: 161 VA
 - Global active power: 121 W
 - Battery output voltage: 13 V
- Environment:** LUC
- Synoptic:** Line Interactive UPS diagram showing Master output, Load segment #1, and Load segment #2.
- Graph - 2 hours:** A line graph showing power and load levels over time, with a timestamp from 06/03/10 - 7:49:16 am to 06/03/10 - 9:49:16 am.
- Statistics - 7 days:** A section for viewing 7-day statistics.
- Events:** A section for viewing device events.

The status bar at the bottom indicates: OK: 13, Warning: 2, Critical: 4, Unknown: 12. The last event is: 05/31/10 - 8:05:43 am - 166.99.224.43 - End of UPS shutdown imminent alarm.

The **Events → Event List** view allows you to view the device events.

2.3 Windows Installation

2.3.1 Graphical installation

Run the “Intelligent Power® Protector” package under an administrator account.



A Web browser is automatically displayed (enter **admin** as Login / **admin** as Password and click on the **Login** button).

Note:

If the browser does not open as planned, it should be started manually and pointed to <http://127.0.0.1:4679>

2.3.2 Silent installation

Installation with command line mode (without user interaction):

e.g.:

```
<ipp package name> -install -silent
```

Once the installation is completed, open a Web browser with the following url
<http://<@IP>:4679/>

<@IP> is the IP address of the machine hosting IPP

Notes:

- To configure the IP address of the Power Source you can use the Intelligent Power® Manager mass configuration feature.
- `-help` option describes the different options available (refer to the next screenshot)

```
Usage: d:\temp\ipp_win_1_10_045.exe [COMMAND] [OPTION]...
Available commands:
  -install:      launches the installation process (default).
Available options:
  -debug:       displays debugging information on the console.
  -dir:         specifies installation folder.
  -silent:      install the application silently.
                Installation folder can be provided with -dir
```

2.3.3 Installation Result

- If you install a new Intelligent Power[®] Protector release without uninstalling the old one you will keep your product settings.
- At the end of the installation, the following shortcuts are created in the group:
Start → Programs → Eaton → Intelligent Power Protector

Name	Description
Open Eaton Intelligent Power Protector	Opens the "Intelligent Power [®] Protector " web page from default browser
Start Eaton Intelligent Power Protector	Starts the service
Stop Eaton Intelligent Power Protector	Stops the service
Uninstall Eaton Intelligent Power Protector	Uninstalls the Program

- A service called « Eaton Intelligent Power Protector» is also created for the Database Acquisition Engine.
This service automatically starts on machine boot-up.
This service provides the Web Interface.
- An alarm notification box, accessible from the System Tray icon displays the alarms on the local computer.

2.3.4 Uninstalling the Product

- From the **Add/Remove** programs item of the control panel, execute the "Eaton Intelligent Power Protector Vx.xx" package.
- You can also uninstall from the shortcuts:
Start → Programs → Eaton → Intelligent Power Protector → Uninstall Eaton Intelligent Power Protector.
This will remove the product and the custom files if you confirm it.

2.4 Linux Installation

Introduction

IPP for Linux is available both in native package form (.deb or .rpm) and as a generic installer for Command Line Interface (CLI).

2.4.1 Native installation on a RedHat, SuSe, Mandriva or derivative system:

1) Graphical installation

To install graphically, double click on the “Intelligent Power® Protector” .rpm package, The system will prompt for the root password, and then launch a graphical frontend, like RedHat's Package Installer below:



2) Command line installation

To install from a command line, use the following command (as root):

```
$ rpm -i ipp-linux_X.Y.Z.rpm
```

For example:

```
$ rpm -ivh ipp-linux-1.10.032-1.i386.rpm  
Preparing... ##### [100%]  
 1:ipp-linux ##### [100%]
```

Once the installation is completed, open a Web browser with the following url <http://<@IP>:4679/>
<@IP> is the IP address of the machine hosting IPP

2.4.2 Native installation on a Debian or derivative system:

1) Graphical installation

Pre-requisite: On Debian Lenny, there is no default graphical installer present.

So you should either use the command line installation described below, or install the package "gdeb" and "gdebi" and restart your graphical session to be able to complete the present procedure.

Note: This is a known Debian bug, which is registered in the Debian Bug Tracking System:

<http://bugs.debian.org/585183>

To install graphically, double click on the "Intelligent Power[®] Protector" .deb package.

The system will prompt for the root password, and then launch a graphical frontend, like Gdebi below:

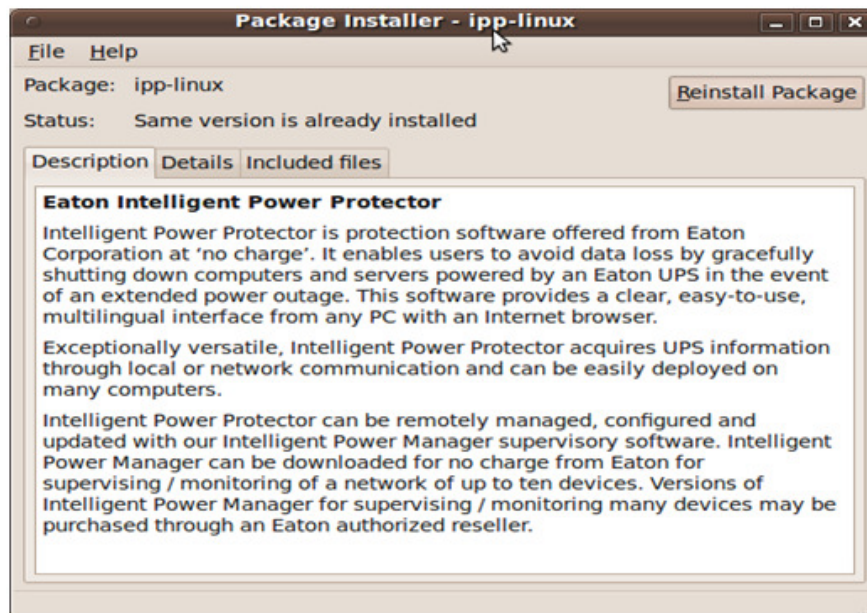

Click on the « Install Package » button. Once the installation is completed, open the menu « Application → Eaton → Intelligent Power Manager → Open » (in Gnome) and follow the « Configuration » chapter.

2) Command line installation

To install from a command line, use the following command (as root):

```
$ dpkg -i ipp-linux_X.Y.Z.deb
```

For example:

```
$ dpkg -i ipp-linux_1.10.032-1_i386.deb
(Reading database ... 352242 files and directories currently installed.)
Preparing to replace ipp-linux 1.10.032 (using ../ipp-linux_1.10.032-1_i386.deb)...
Unpacking replacement ipp-linux ...
Setting up ipp-linux (1.10.032)...
```

Once the installation is completed, open a Web browser open a Web browser with the following url

<http://<@IP>:4679/>

<@IP> is the IP address of the machine hosting IPP

2.4.3 Generic installation on Linux

If your system doesn't derive from RedHat (using .rpm) or Debian (using .deb), you can install **IPP** using the generic package.

Note: this method is only supported from the command line.

To install from a command line in interactive mode, use the following command from where the generic installer is located (as root):

```
$ ipp-linux-1_10_035-i386.run -install
```

For silent installation, add the `-silent` parameter as shown below (as root):

```
$ ipp-linux-1_10_035-i386.run -install -silent
```

Once the installation is completed, open a Web browser with the following url
<http://<@IP>:4679/>

<@IP> is the IP address of the machine hosting IPP

2.4.4 Uninstalling the Product

As for the product installation, if you have chosen the native packages, you can use your favourite packages management application to remove the « ipp-linux » package.

You can also do the same from the command line.

For example, on RedHat and derivatives, use:

```
$ rpm -e ipp-linux
```

On Debian and derivatives, use:

```
$ dpkg -r ipp-linux
```

Note: After uninstalling the native .deb or .rpm packages, some user's configuration and data are not removed, due to technical constraints.

If you want to fully remove these, use (as root):

```
$ rm -rf /usr/local/Eaton/IntelligentPowerProtector
```

If you have chosen the generic installer, use the following command for interactive uninstall (as root):

```
$ /installation/path/mc2 -uninstall
```

For silent uninstall add the `-silent` parameter as shown below (as root):

```
$ /installation/path/mc2 -uninstall -silent
```

3 Configuration

3.1 Intelligent Power® Protector Settings

Start the "Intelligent Power® Protector" main graphical interface from the previously created shortcut, and then click on the **Settings-> Auto Discovery** menu item.

3.1.1 Discover the UPSs connected through USB/Serial

The first discovered UPS connected through (RS232 or USB) is automatically assigned as the Power source (the Status icon is Green - )

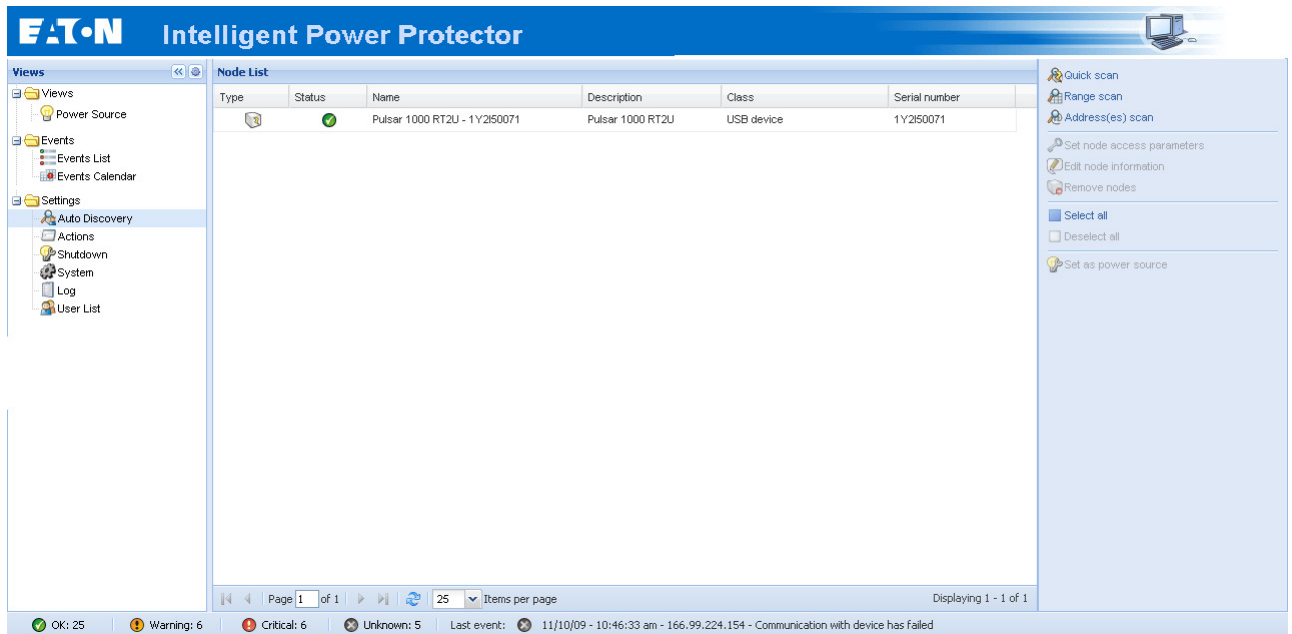

3.1.2 Discover the nodes Connected on the Network



From the **Settings** → **Auto Discovery** item; the following discovery methods are available:

- Quick Scan (automatically performed when application starts)
- Range Scan
- Address Scan

Notes:

- Each network node (Web/SNMP Card ...) must have a valid IP address (or a DNS name) in the range that you have entered for auto-discovery. Refer to the compatibility list. “Intelligent Power[®] Protector” automatically receives the alarms (through notification or polling)
- Required Connect UPS XSlot/BD configuration:
 - ⇒ Set the IPP discovery password to the same value as the Web /SNMP read community name (default is public)
 - ⇒ In ConnectUPS Write Access Managers control menu (via telnet, ssh or serial connection): disable SNMP access restricted by IP/Hostname (this is the default setting since firmware version 2.02) or configure it correctly (IPP has to be configured in trusted host list)
- Required PXGX 2000 configuration:
 - ⇒ Set the IPP discovery password to the same value as the PXGX2000 read community name (default is public)
 - ⇒ In PXGX2000 Access control page: disable SNMP access restricted by IP/Hostname or configure it correctly (IPP has to be configured in trusted host list)
 - ⇒ In PXGX2000 Take care to configure PXGX2000 in SNMP V1 or SNMP V1 + V3
- The Quick scan request is a Broadcast frame on 4679 IANA reserved port and 69 standard TFTP port. Using the Quick scan operation, you will discover through broadcast within a few seconds following Web/SNMP Cards (NMC P/N 66102, Connect UPS MS P/N 103 006 826, Connect UPS XSlot P/N 116750221-001, PXGX 2000 P/N 103005868-5591, ...)
- For the nodes outside of the Network segment, please perform the discovery based on IP address ranges (**Range scan**)
- Address Scan performs a single address scan

The discovered UPS connected through (Network) are not automatically assigned as the Power source (you have to select the node and click on the button **Set as Power Source**).

- The “Edit shutdown configuration” window opens automatically when the Power source is set. Please refer to the next paragraph to configure correctly the parameters.
- Once the power source is configured, the icon becomes Green  or Grey  if the communication fails).

EATON
Intelligent Power® Protector

[Logout 'admin'](#)
[Help](#)

Views

- Views
- Power Source
- Events
 - Events List
 - Events Calendar
- Settings
 - Auto Discovery
 - Actions
 - Shutdown
 - System
 - Log
 - User List

Node List

T...	St...	Name	Mac Addr...	Class	Location	Contact
		166.99.224.112	00:20:85:...	Network Managem...	Computer ...	Compute...
		166.99.224.178/...		Intelligent Power Pr...		
		166.99.224.150/...		Intelligent Power Pr...		
		166.99.224.119	00:20:85:...	Network Managem...	1A09	Luc
		166.99.224.88	00:20:85:...	Network Managem...	Computer ...	Compute...
		166.99.224.171	00:06:23:...	Network Managem...	Eric Office	Eric
		166.99.224.92	00:06:23:...	Network Managem...	Sous le b...	Seb
		166.99.224.43		ConnectUPS Web/...	Bureau eric	eric
		166.99.224.185		Power Xpert Gate...	Your Loc...	Your Na...
		166.99.224.155	00:20:85:...	Network Managem...	Computer ...	Compute...

Page 1 of 1
25 Items per page
Displaying 1 - 10 of 10

- Quick scan
- Range scan
- Address(es) scan

- Edit node information
- Remove nodes

- Select all
- Deselect all

- Set as power source

OK: 13
 Warning: 2
 Critical: 4
 Unknown: 12
 Last event: ✔ 05/31/10 - 8:05:43 am - 166.99.224.43 - End of UPS shutdown imminent a

3.1.3 Shutdown

3.1.3.1 Introduction

Intelligent Power® Protector provides **local computer graceful shutdown** with an acquisition through:

- USB/Serial
- or Network (Web/SNMP Cards)

To configure shutdown, proceed as follows:

- Login with an administrator user profile
- From the **Settings** menu Item, select the **Shutdown** menu item then the following page is displayed:

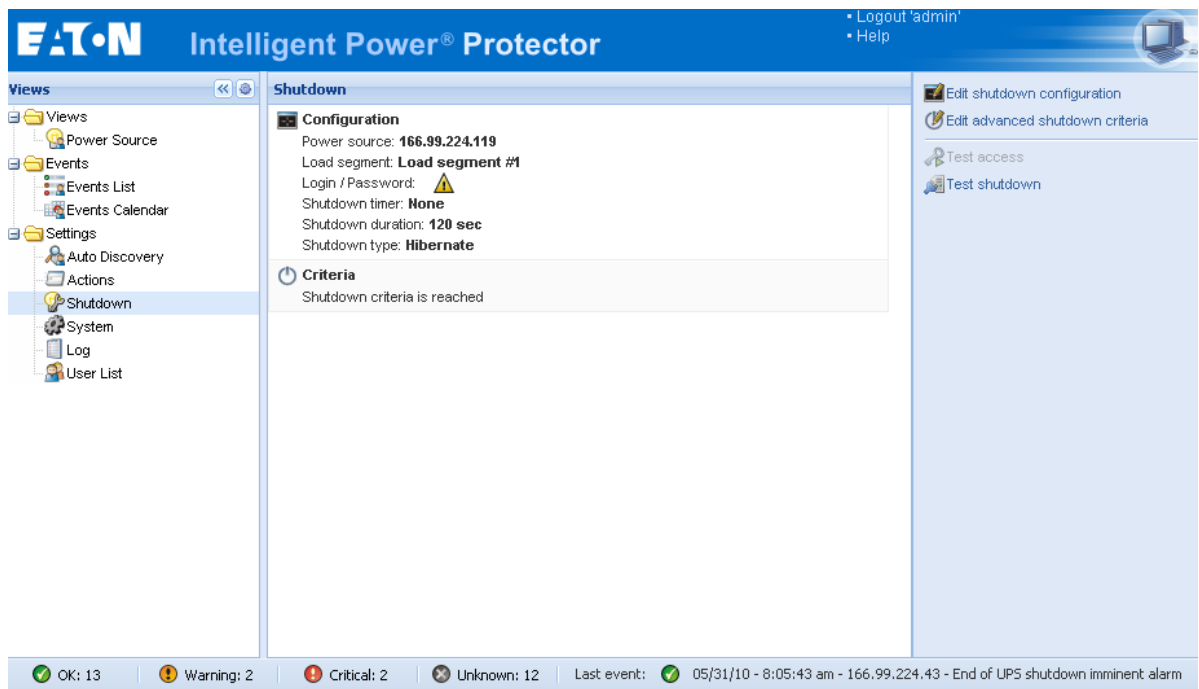

From this page, the configuration options are provided:

- Edit shutdown configuration.
- Edit advanced shutdown criteria.
- Test Access.
- Test shutdown.

These configuration options are described hereafter.

3.1.3.2 Edit Shutdown Configuration

To configure Shutdown parameters, perform the following actions:

- Click on **Edit shutdown configuration**.

- In the **Power source** field select the UPS that powers the computer hosting Intelligent Power® Protector (This settings is also accessible through **Settings -> Auto-Discovery -> Set as PowerSource**)
- Check other parameters.
- Click on Save

Other parameters:

Load Segment: (Optional) the load segment that powers the server hosting IPP

Access parameters: (When Power Source is managed through the network)

- If the Power source is a Web/SNMP Cards (NMC P/N 66102, Connect UPS MS P/N 103 006 826, 66103), Login and password are needed only if Intelligent Power® Protector has to set values in the Web/SNMP Card. (e.g. when changing the shutdown duration value)
- If the Power source is another Intelligent Power® Protector with “shutdown controller” feature activated, then Login and password are **mandatory**. The Login must be the “admin” account.

Shutdown duration: The shutdown delay needed to properly shut down the computer.

Shutdown timer: (Optional) The time period from the time of the power failure until the launch of the UPS shutdown sequence.

Shutdown type:

- **Hibernate** (default option)
 If available with your operating system, is better to use the hibernation feature (first available with Windows 2000) as there are a number of advantages. If the system is shut down, all work in progress and system information are automatically saved to the disk. The computer itself is also de-energized. When mains power returns, all the applications re-open exactly as they were and the user placed back in their work environment.
 Hibernate function must first have been activated in the operating system. In the power options on the Windows control panel, check that **hibernate** option is activated on the Hibernate tab sheet.
 Note: If you select hibernate, but your computer does not have this function, Intelligent Power® Protector will still protect the installation by carrying out the normal (default) shutdown.
Note: For Windows Vista, please refer to the FAQ section of this manual.

- **Shutdown.** This option shuts down your applications and the system, but does not de-energize the computer. The system offers the user the choice to de-energize the computer, in which case it is the UPS that cuts power.
 On most computers, this configuration is necessary if you want the server to restart as soon as mains power returns.

- **Power-off** This option shuts down your applications and the system, and de-energizes the computer. This configuration is advised if you wish to be on hand when the system re-starts. (or for load shedding)

- **Script:** This option manages the shutdown in a custom script that you can create to fit with your own shutdown sequence.
 You can integrate the standard Windows shutdown command (more info with shutdown /? in a Windows Command Line interpreter). **Shutdown script:** the absolute path of the script.

Outlet shutoff Active: Using this option, IPP will send a delayed shutoff command to the outlet. This delayed command is sent to the UPS at the beginning of the shutdown sequence, and this is the point of no return for this sequence. The outlet is turned off at the end of the shutdown sequence.

Shutdown sequence trigger:

When a power utility failure occurs, the shutdown sequence is started as soon as the first of the two following condition is reached.

- After the **Shutdown timer** (if configured).
- When **NMC or UPS shutdown criteria is reached** (UPS / NMC Card Decision according to many criteria see next figure)

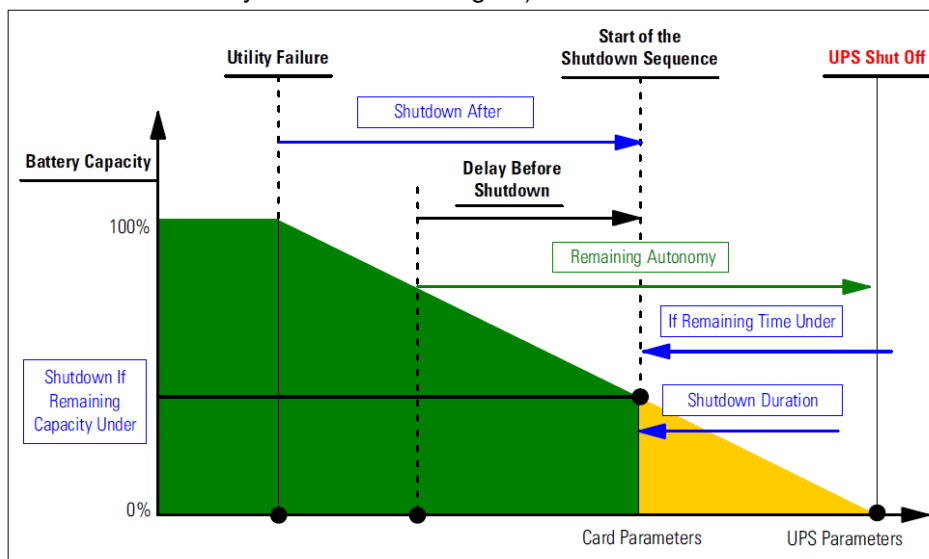

3.1.3.3 Edit advanced Shutdown Criteria

Edit advanced Shutdown Criteria opens the “Edit advanced Shutdown Criteria” window:

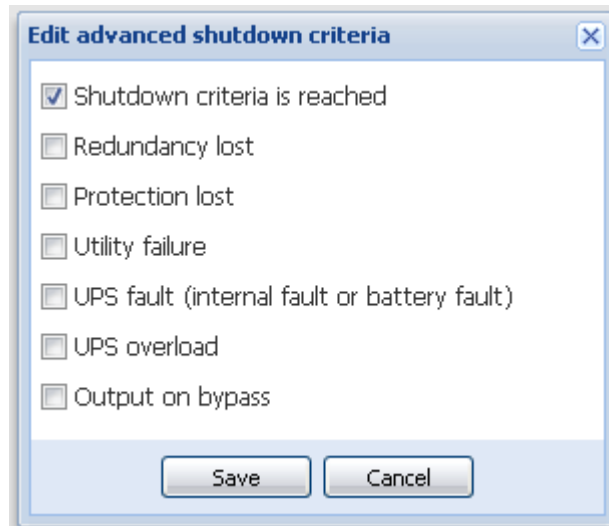

Criteria definition:

- **Shutdown criteria is reached:** (enabled by default) this is the standard shutdown sequence taking into account “time based criteria” and “UPS low battery level criteria”

In addition, the user can also select one or several events in the following events list. If these events are selected, they will trigger an immediate shutdown sequence when they occur.

- **Redundancy lost** (For Eaton MX Frame only)
- **Protection lost** (For Eaton MX Frame only)
- **Utility failure**
- **UPS fault (internal fault or battery fault)**
- **UPS overload**
- **Output on bypass**

3.1.3.4 Test access

Test access checks if “Login and password” are correctly configured so that:

- IPP can update his shutdown configuration on the **card** or
- IPP can remotely access to the IPP **shutdown controller**.

3.1.3.5 Test shutdown

Test shutdown starts a shutdown procedure (According to the IPP parameters)

3.1.4 Shutdown Use case

According to different architecture, we describe several typical use cases that will help you to configure properly the shutdown sequence according to your needs.

3.1.4.1 Architecture #1 (local attached UPS through serial /USB)

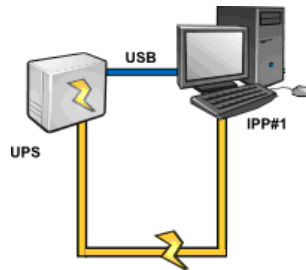

Use Case #1: You want to keep your computer hosting IPP#1 alive as long as possible.

- ⇒ This is the default IPP#1 configuration. The next screenshot illustrates this IPP default configuration available from **Settings -> Shutdown -> Edit Shutdown Configuration**.

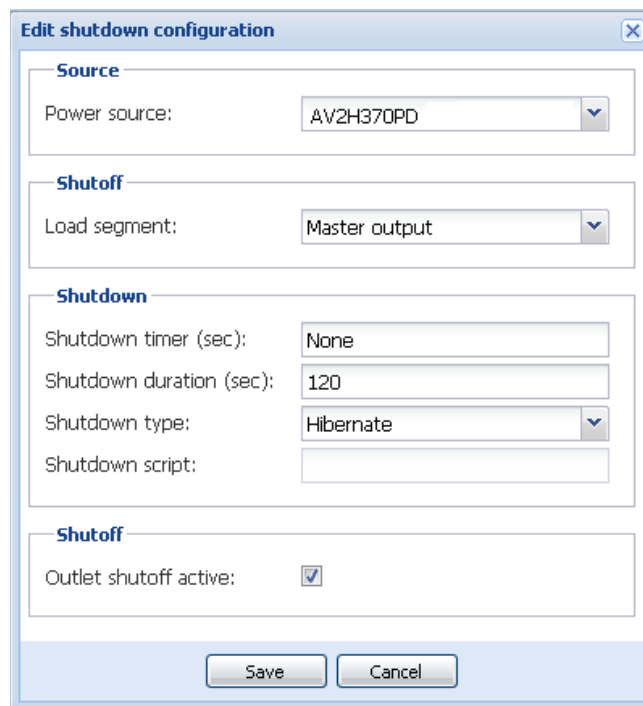

Use Case #2: To save battery backup time, you want to perform load shedding (stop your computer after a predefined time)

- ⇒ Configure a **Shutdown timer** value on IPP#1 (this configuration parameter is available from **Settings->Shutdown->Edit Shutdown Configuration**)

3.1.4.2 Architecture #2 (Network attached UPS Web SNMP Card)

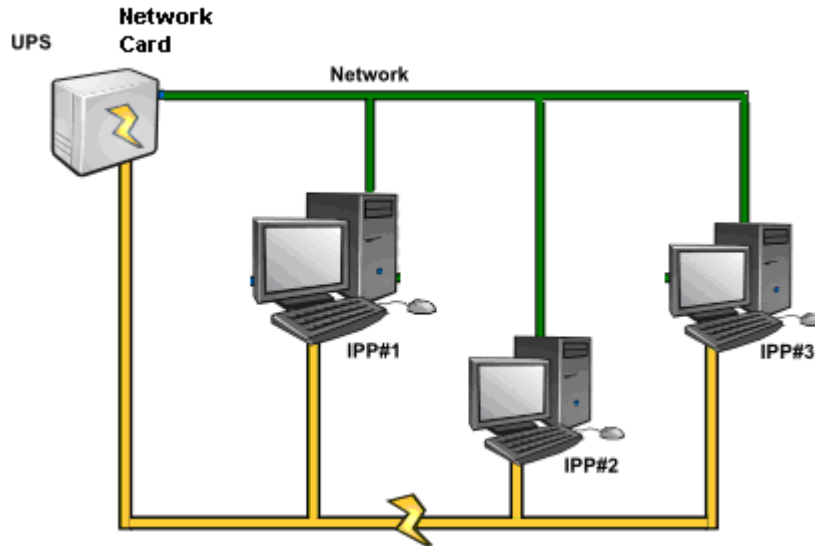

Use Case #1: You want to keep all your computers alive as long as possible

⇒ This is the default configuration for the IPPs and the NMC

IPP default configuration is available from **Settings -> Shutdown -> Edit Shutdown Configuration**. e.g. 66102 and 103 006 826 NMC default shutdown configuration is available from **UPS-> Shutdown Configuration** as illustrated on next screenshot:

Network Management Card

UPS

- UPS Properties
- UPS Control
- Weekly Schedule
- Shutdown Parameters

Logs and Notification

- Measurements
- Event Log
- System Log
- Email Notification

Settings

- Network
- System
- Notified Applications
- Access Control
- Time
- Firmware Upload

Shutdown Parameters				Help
Pulsar M 2200		Computer Room		
Output	On battery	System Shutdown	Restart	
Master	<p>Shutdown</p> <p>if Remaining time under: <input type="text" value="180"/> sec</p> <p>if Capacity under: <input type="text" value="20"/> %</p> <p><input type="checkbox"/> after: <input type="text" value="30"/> min</p>	Shutdown duration: <input type="text" value="120"/> sec	If Capacity exceeds: <input type="text" value="15"/> %	
Group1	<p>Switch Off</p> <p>after: <input type="text" value="900"/> sec</p> <p>if Capacity under: <input type="text" value="75"/> %</p>	Shutdown duration: <input type="text" value="120"/> sec	Switch On after: <input type="text" value="30"/> sec	
Group2	<p>Switch Off</p> <p>after: <input type="text" value="1800"/> sec</p> <p>if Capacity under: <input type="text" value="68"/> %</p>	Shutdown duration: <input type="text" value="120"/> sec	Switch On after: <input type="text" value="18"/> sec	
<input checked="" type="checkbox"/> Show advanced parameters				
Save modified settings:				<input type="button" value="Save"/>

Use Case #2: To save battery backup time, you want to stop all your computers after a predefined time.

- ⇒ On the NMC, configure a Shutdown Criteria.
e.g. 66102 and 103 006 826 NMC shutdown configurations are available from **UPS-> Shutdown Configuration**
Note: In this case the computer automatic restart is guaranteed.

Use Case #3: *You want to perform load shedding on the specific computer hosting IPP#2 (i.e. stop the computer hosting IPP#2 after a predefined time)*

- ⇒ On IPP#2, configure a **Shutdown timer** value (this configuration parameter is available from **Settings->Shutdown->Edit Shutdown Configuration**)
Note: In this case the automatic restart for the computer hosting IPP#2 is not guaranteed

Note: Use Case 3 can be combined with Use Case 1 or Use Case 2

3.1.4.3 Architecture #3 (Network attached UPS through Shutdown Controller)

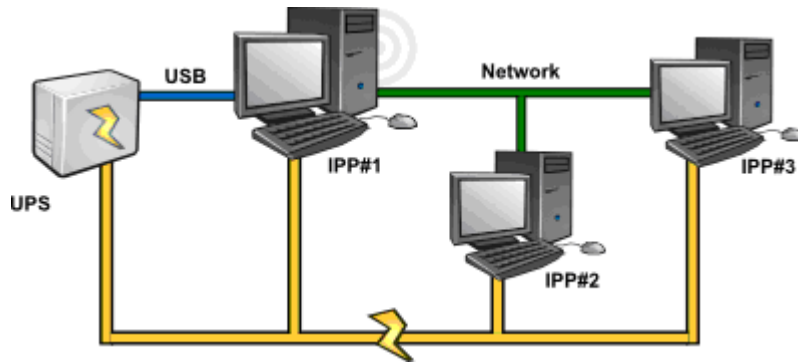

Use Case #1: You want to keep all your computers alive as long as possible.

- ⇒ This is the default shutdown configuration for the Shutdown Controller IPP#1 and other IPPs
IPP default configuration is available from **Settings -> Shutdown -> Edit Shutdown Configuration**.

Use Case #2: To save battery backup time, you want to stop all your computers after a predefined time.

- ⇒ On IPP#1 (Shutdown Controller) configure a **Shutdown timer** value. (this configuration parameter is available from **Settings->Shutdown->Edit Shutdown Configuration**)
Note: In this case the automatic restart for all the computers is guaranteed

Use Case #3: You want to perform load shedding on the specific computer hosting IPP #2 (stop the computer hosting IPP#2 after a predefined time).

- ⇒ On IPP#2, configure a **Shutdown timer** value (this configuration parameter is available from **Settings->Shutdown->Edit Shutdown Configuration**)
Note: In this case the automatic restart for the computer hosting IPP#2 is not guaranteed

Note: Use Case 3 can be combined with Use Case 1 or Use Case 2

Use Case #4: Typical example with 4 computers. According to the servers' roles, you may want to shutdown the servers at different times:

Computer hosting IPP#1: is directly attached to the UPS (USB/Serial) The shutdown Controller has to be installed on the server that will be the last one to shutdown.

Note: On Pulsar series this computer has to be powered by the master outlet.

Computer hosting IPP#2: is a computer that requires a long delay to shutdown (e.g. hosting database or VM-Ware)

Computer hosting IPP#3: is a computer that requires being the last one to be shutdown (as other servers depend on it) (e.g. File server)

Computer hosting IPP#4: is another server that has be stopped before computer B or C (Web server)

*or this computer can also be stopped for load shedding purpose.
(Workstation)*

⇒ Recommended configuration:

- On IPP#1: Configure **Shutdown Timer** to None and **Shutdown Duration** to 120 s
- On IPP#2: Configure **Shutdown Timer** to 180 s and **Shutdown Duration** to 180 s
- On IPP#3: Configure **Shutdown Timer** to None and **Shutdown Duration** to 120 s
- On IPP#4: Configure **Shutdown Timer** to 120 s and **Shutdown Duration** to 120 s

The following time diagram summarizes this configuration:

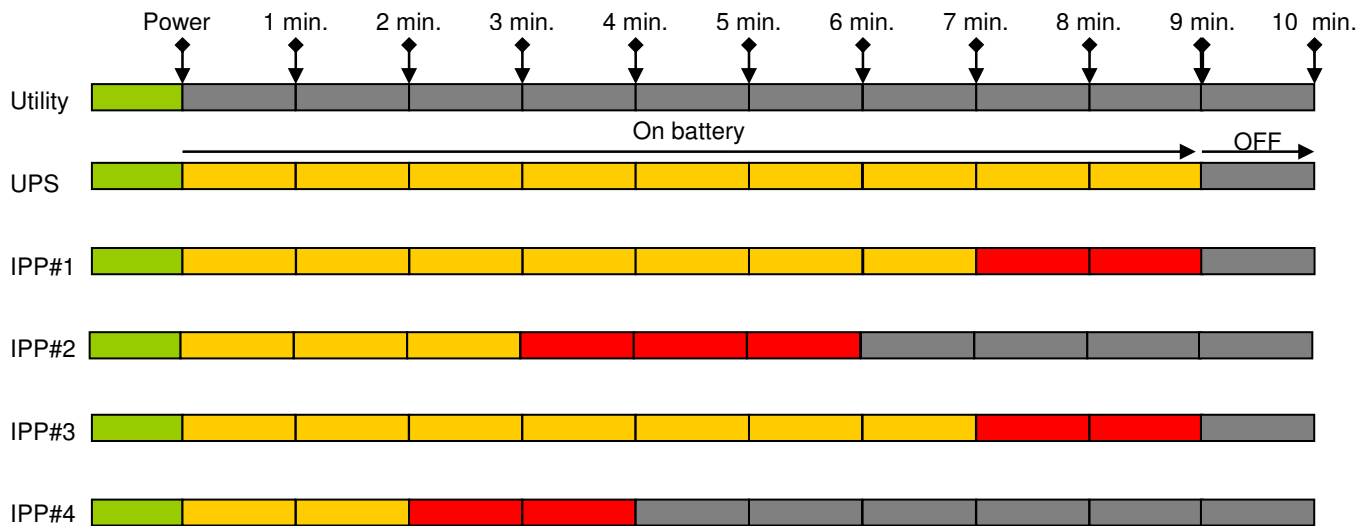

3.1.5 Configure Actions

You can define the way users will be notified when node events happen.

From the **Settings** → **Actions** item; the following channels are available:

- E-mail
- Execute script/program
- Notification to the local alarm notification box, available from the System Tray icon.

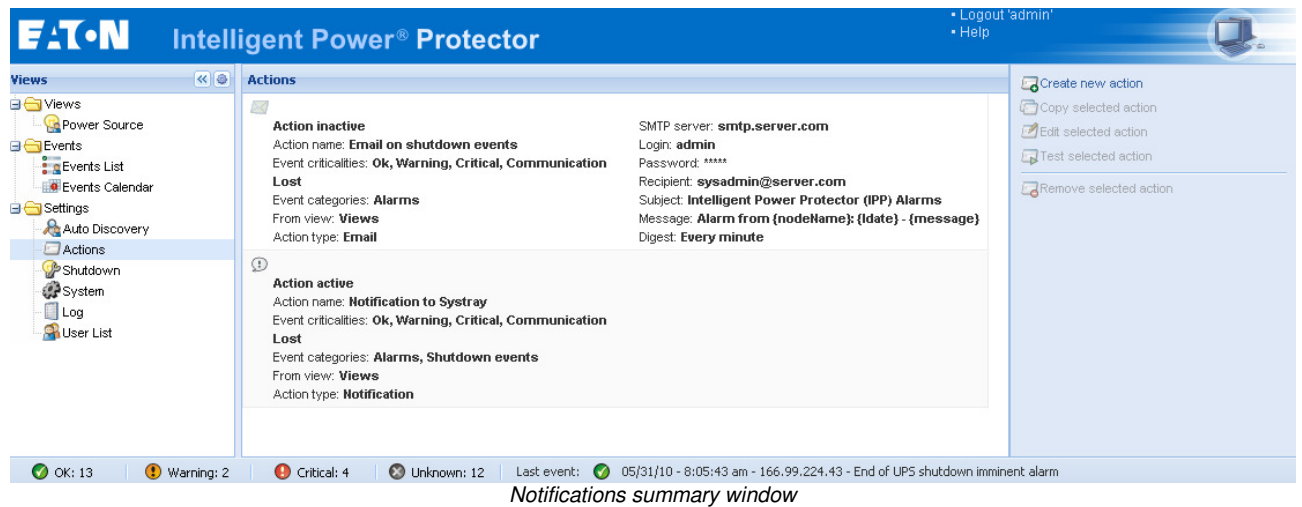

The **Create new action button** will display following interface:

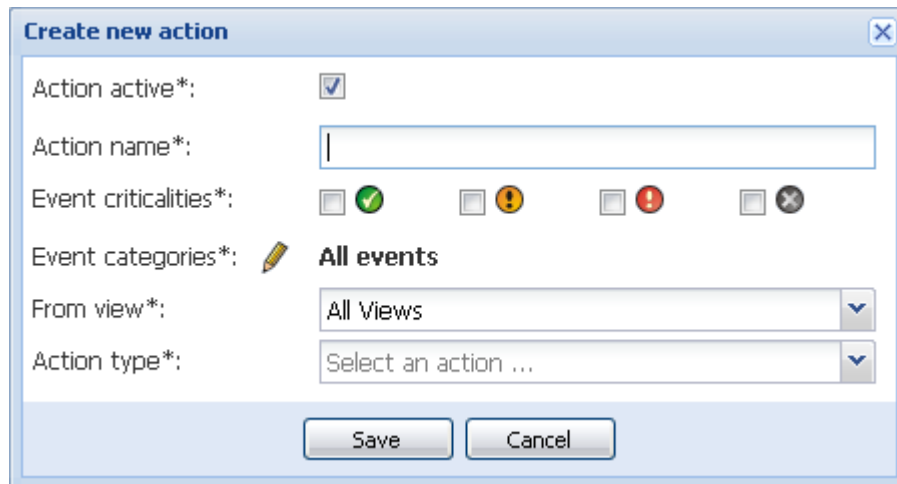

Notes:

- The "*" fields are required.
- Clicking on the pen icon starts an assistant to fill the field.

Action active: enables/disables the action.

Action name: user friendly name for the action.

Events filter:

You can filter the action according to:

- The **Event criticalities**. (Critical, Warning, Normal, Communication Lost).
- The **Event category** (All Events, Alarms, Shutdown events, Power events, Measures) refer to the list hereafter.
- The view that triggers the event (**From view**).

Note on Event Criticality parameter:

With this parameter, you can filter the notification according to the event level. Refer to the event list provided below in this document. If you select “Critical” as filter you will not receive the associated “Normal” event informing that the device status changes from “Critical” to “Normal”.

Action type: you can select following action: (Email / Command / Notification). According to your choice, specific settings are available for each action. The configuration of these 3 actions is detailed hereafter.

Detailed Alarms and events list in “Event category”:

Alarms:

- Utility failure
- Communication lost
- Shutdown Imminent
- Battery Low
- Internal Failure
- Overload
- Output On/Off
- Outlets On/Off
- Battery Fault
- On Automatic Bypass
- On Manual Bypass
- Redundancy Lost
- Protection Lost

Shutdown Events:

- Utility failure
- Battery Low
- Shutdown Imminent
- Local Run Time to Shutdown

Power Events:

- Output Percent Load
- Output Apparent Power
- Output Active Power
- Output Power Factor
- System Defined Output Overload Alarm

Measures:

- Output Percent Load
- Battery Remaining Capacity
- Battery Run Time to Empty
- Main 1: Voltage, Current and Frequency
- Main 2: Voltage, Current and Frequency
- Output: Voltage, Current and Frequency
- Output Apparent Power

- Output Active Power
- Output Power Factor

E-mail:

This action is not active by default. Some of the fields are preconfigured by default.

Edit action

Action active*:

Action name*: Email on shutdown events

Event criticalities*:

Event categories*: **Alarms**

From view*: All Views

Action type*: Email

Settings

SMTP server*: smtp.server.com

Login: admin

Password:

Recipient*: sysadmin@server.com

Sender: Computer 2

Subject: Intelligent Power Protector (IPP) Alarms

Message: Alarm from {nodeName}: {ldate} - {message}

Digest*: Every minute

Save Cancel

For the “generic” fields at the top of the window, please refer to “create new action” section

Specific “email action” settings:

- **SMTP Server:** To receive emails on UPS events you have to indicate the SMTP server IP address
- **Login, Password:** authentication information of the SMTP server
- **Recipient:** Receiver Email address.
Note: you can specify multiple receivers by separating them with coma.
- **Sender:** (Optional field) the email sender
Note that your SMTP server may require a valid email address.
- **Subject:** The email subject (can be customized with pre-defined variables).
- **Message:** The email message body (can be customized with pre-defined variables).
- **Digest:** you can specify that you want to receive a consolidation of the alarms that occurred during a delay that you can choose (if you specify **none**, each alarm will generate an e-mail. With this setting you will receive more emails for the same number of events.
Possible values are: None / Every 10 seconds / Every minutes / Every hour / Every day

Notes:

- It is possible to duplicate an existing action already configured and just change some parameters.
- For advanced use, you can Customize the **subject** and **Message** e.g. if you have to translate an e-mail into an SMS (using an email to SMS external provider).
Clicking on the pen icon starts the **Edit message** assistant to fill the field with some variables.
Click on the  button to add a variable.

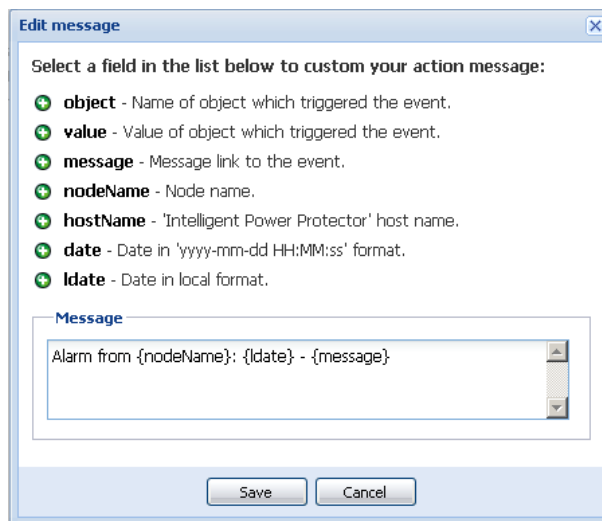

Command (Execute script/program):

In order to execute a program on UPS events the program path will be required.

Example to play sound alarms on events:

Create a batch command file containing the command: `mplay32.exe /play /close`

`C:/WINDOWS/Media/<sound>.wav`

Create an action of type command calling this batch file.

Notes:

- **For Windows**, the program is executed under the SYSTEM account. For the right execution of some privileged commands, you may have to apply following procedure:
It may be necessary to modify the context before certain actions can be run.
To allow a user to run specific tools and programs with permissions that are different from those assigned to the user's account use the Windows "RunAs" Command which allows you to save the password (Windows XP Service Pac 2 and more recent versions).
Use the following Microsoft command:
`runas /profile /user:<my login> /savecred <my_program.exe>`
On first execution a password is required, it is saved for subsequent executions.
- **For Linux**, the IPP process is running under root privilege (`sudo` command is not needed to execute a program or shell script).

Notification (Alarm box notification):
The Notification action is active by default.

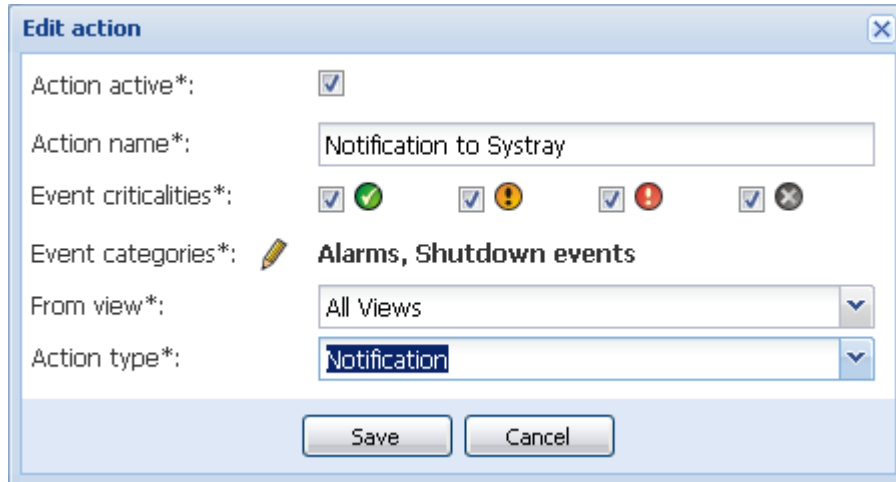



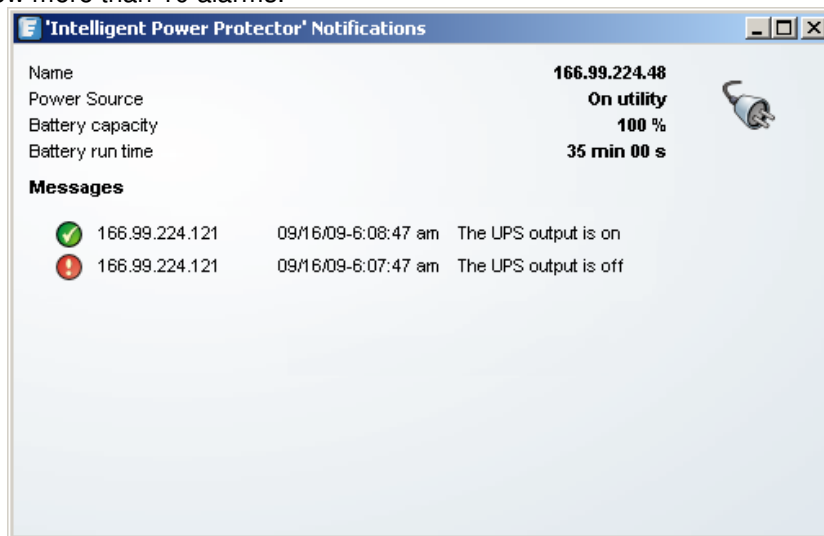

The alarms are displayed on the local computer in an alarm box. This alarm box displays the last 10 alarms. It takes the focus when a new alarm occurs. From the event section you can view more than 10 alarms.



The alarm notification box is accessible from the System Tray icon. Double click on the icon to open the window that displays the alarms on the local computer.

Note: right click on the icon doesn't display any menu.

If a Power source has been declared, System Tray Icon can have following states:

	The System Tray Icon correctly receives alarms from Intelligent Power [®] Protector (AC is present on the Power source)
	The System Tray Icon correctly receives alarms from Intelligent Power [®] Protector (The Power Source runs in battery mode)
	The System Tray Icon correctly receives alarms from Intelligent Power [®] Protector (A Warning event occurred on Power Source)
	The System Tray Icon correctly receives alarms from Intelligent Power [®] Protector (A critical event occurred on Power Source)
	Communication with Power source has failed

Advanced events and actions customization:

In Intelligent Power® Protector installation folder, you can see a *configs/scripts* folder containing a sample user-defined action script (*sample_user_script.js*).

You have the possibility to modify this script or create new scripts that define very specific events and actions. The sample script provides details about the expected structure and syntax for defining new actions and triggers.

To activate the execution of a script you have to set the `enabled` property to `true` as follows:

```
UserScript =  
{  
  name: "MyScript",  
  enabled: true, // Set this property to true to enable the script
```

3.1.6 Configure User Accounts

Multiple user accounts can be configured.

From the **Settings** menu Item, select the **User List** item, then perform the following steps:

- Click on Add user.
- Set the **User Login** and the **User password**.
- Select the **User's Profile** level. The following levels are available:
 - => **admin** (the user will be able to access all the features)
 - => **user** (the user will only access the supervision and is not able to set parameters to the system or nodes).
- Click on **Create new user** button.



User Accounts window

Intelligent Power® Protector contains a default Administrator profile with:

- admin as login
- admin as password

Warning:

- For security reasons, it is strongly recommended to change default password immediately after the installation.
- A Popup warns you on security if the password contains less than 8 characters.

Notes:

- The Login and Password is case sensitive
- The original admin account login value is fixed (admin) and its Password has to be modified
- There is no limit in the accounts number

3.1.7 System settings

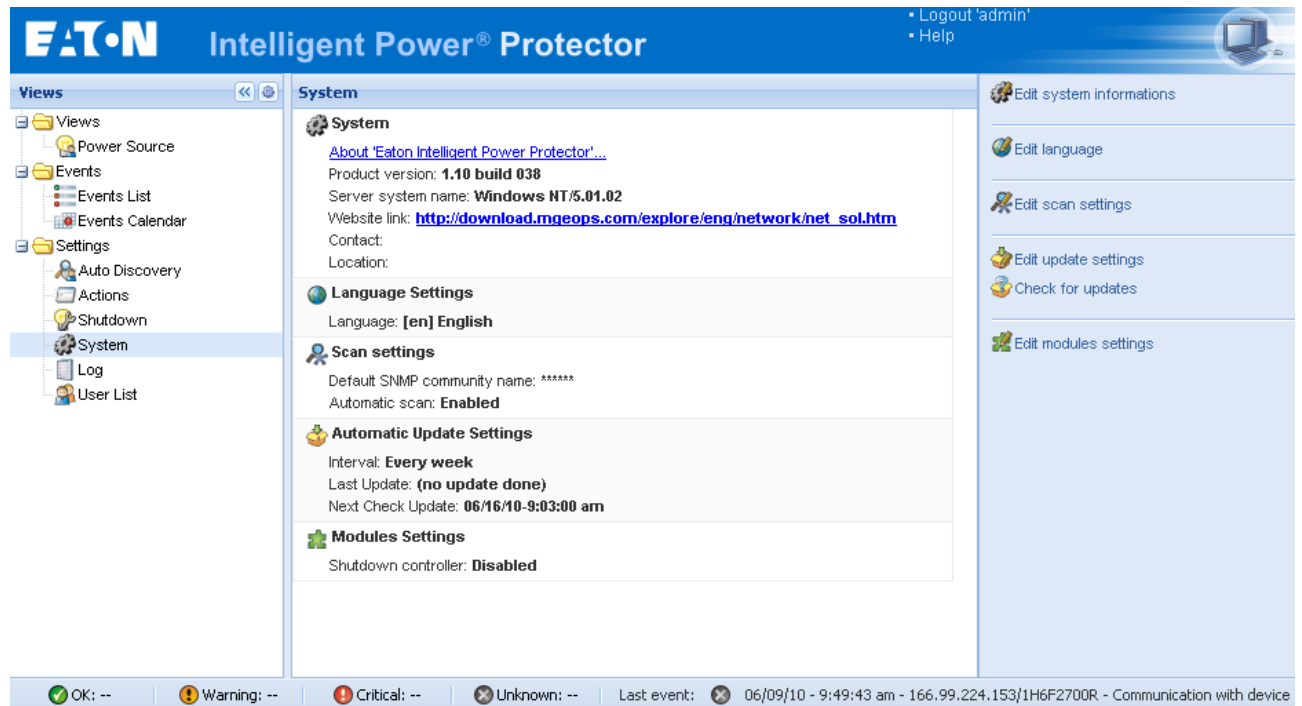

System settings

Select one of the items, and then click on the corresponding button on the right:

- **Edit system information:** to enter contact and location information for IPP software.
- **Edit language** allows the user to change the user language. (Czech, English, French, German, Japanese, Korean, Polish, Portuguese, Russian, Simplified Chinese, Spanish are currently supported)
- **Edit scan settings** changes the default SNMP community name for discovery and enables/disables periodic scan of new nodes.

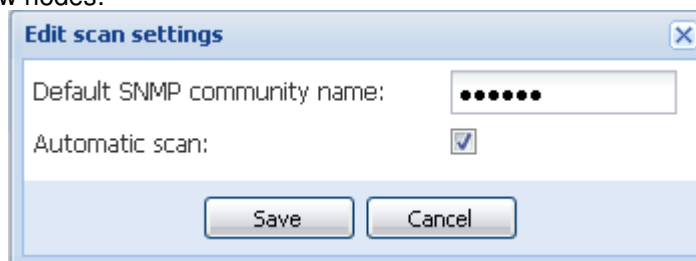

- **Edit update settings** will customize Automatic Updates Features. This feature gives you access to Eaton software updates. Intelligent Power® Protector will always be up to date if you select the **Check automatically** option. When a new software version is detected on www.eaton.com, just follow the wizard instructions.
Notes:
 Intelligent Power® Protector settings will be retained with this operation
 Intelligent Power® Manager can manage updates with large number of computers (refer to chapter 5)
- **Check for updates** will check if a more recent version of the product is available on Eaton Web site
- **Module Settings** enables optional modules (e.g. Shutdown Controller)

3.1.8 Shutdown Controller

3.1.8.1 Introduction

Intelligent Power Protector can acquire UPS alarms from a UPS (**through USB or RS232**) and forward the shutdown alarms to the other Intelligent Power Protectors. This specific Intelligent Power Protector is called the “Shutdown Controller”.

Note: The Shutdown Controller can not acquire information through a SNMP/Web Card.

3.1.8.2 Activating Shutdown Controller feature

You have to activate the **Shutdown Controller** feature on the IPP 1 that relays the alarms (connected to the UPS through USB or RS232).

This option can be activated from **Settings-> System -> Module Setting**

Double click on **Module settings** then check the checkbox.

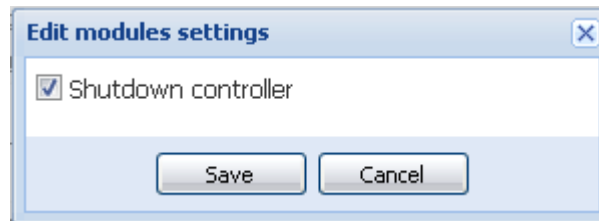

When this feature is activated on one IPP:

- A new view called “Notified Applications” appears in the menu of the **Shutdown Controller** IPP and the IPP top banner is updated with this graphical sign:



- Other IPPs will discover this IPP through a network scan. From these other IPPs configure the parameters in **Setting-> Shutdown-> Configuration**. The main parameters are:
 - * Power Source (indicate the IP address of IPP1 that is the Shutdown Controller)
 - * Load Segment
 - * Login and Password (You must use “admin” account)
 Click on **Save**. Now your IPP is registered in the Notified Application view of the Shutdown Controller (refer to the next chapter).

Example with 3 computers ([refer to the Shutdown Use Case for Architecture #3](#)) :

A UPS is locally connected (through USB) to computer 1 hosting IPP1 (Shutdown Controller)

- the IPP 1 automatically detects its UPS
- the user has to activate the “Shutdown Controller” feature for IPP1
- In IPP2 interface the user will have to indicate the IP address of IPP1 computer, the load segment and IPP1 Login and Password
- In IPP3 interface the user will have to indicate the IP address of IPP1 computer, the load segment and IPP1 Login /Password
- IPP1 will forward Shutdown alarms to remote IPPs (IPP2) (IPP3)
- As a consequence the 3 servers powered by this UPS are protected.

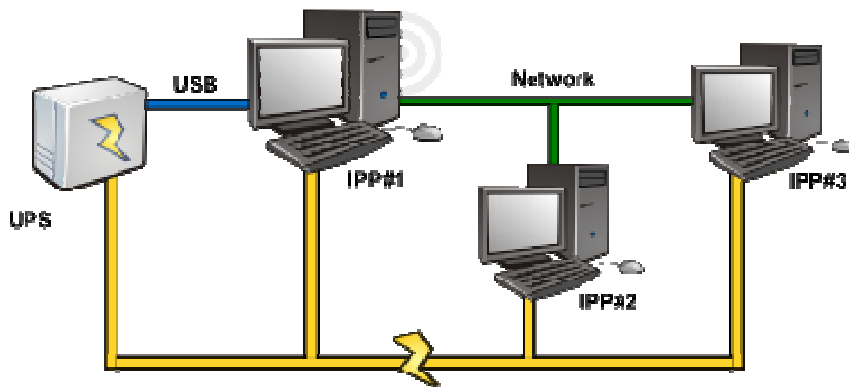

This is the corresponding Power flow view where 1 UPS powers 3 single feed Servers:

3.1.8.3 Notified Application view

The notified application View appears when the Shutdown Controller feature is activated. When the user selects a line, the right hand panels will be refreshed according to the selection.

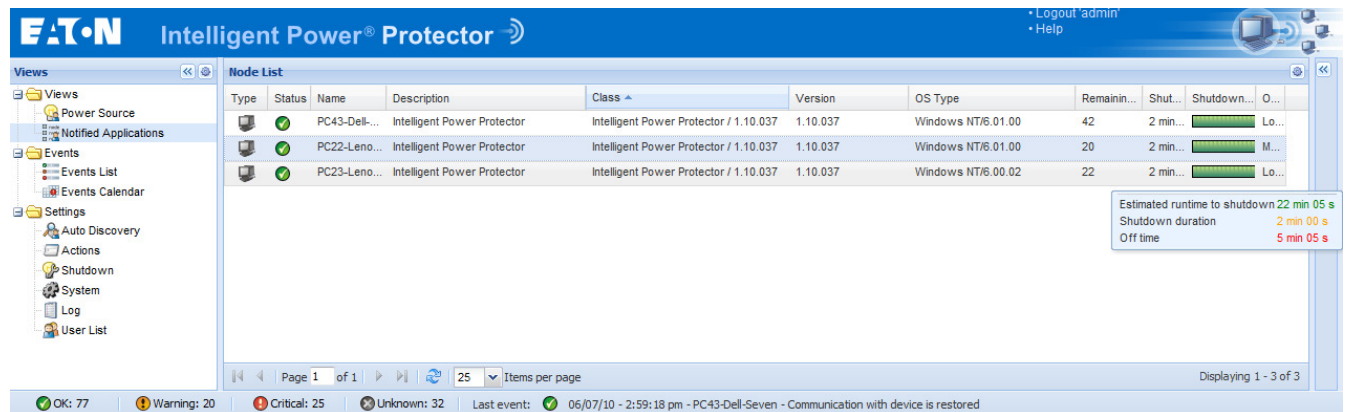

Notified Applications View

Status:

- Green icon indicates that communication is OK between Local and Remote IPP
- Grey icon indicates that communication is lost between Local and Remote IPP

Shutdown Diagram:





The shutdown diagram is a time illustration of the shutdown sequence of the selected computer. It aims to present a visual representation of the shutdown sequencing between the different computers.

- The total width is the remaining runtime to empty of the power source (in case a power failure would happen or is in progress).
- The green part is the runtime to shutdown duration of the computer
- The orange part represents the computer shutdown duration.
- The red part is the computer off time.

Note:

The **Notified Applications** list is persistent.

The status of this remote IPP will change from OK  to Communication Lost  if you uninstall a remote IPP or if there is a communication lost event between the shutdown controller IPP and the remote IPP. With this mechanism the IT administrator will be able to monitor any change in the IT distributed architecture. You can manually remove the IPPs from this list through the **Autodiscovery -> Remove Nodes**

4 Supervision

4.1 Access to the monitoring interface

To monitor the Power Source, start the main “Intelligent Power® Protector” interface. You can access the same interface locally or remotely.

4.1.1 Local access

- From the system where Intelligent Power® Protector is installed, you can use the following shortcut: Start -> Programs -> Eaton -> Intelligent Power Protector ->Open Eaton Intelligent Power Protector
- From a local machine, you can type the following URL in a Web browser
https://127.0.0.1:4680/
or
http://127.0.0.1:4679/

4.1.2 Remote access

- From a remote machine, you can type the following URL in a Web browser
https://<name or IP address of computer hosting IPP>:4680/
or
http://<name or IP address of computer hosting IPP>:4679/
- In SSL mode, accept the certificate (by clicking on Yes)



Accepting the SSL Certificate

e.g. To install the certificate on IE7, you need to perform the following steps:

- > Run IE as an administrator (Right-click the desktop icon)
- > Visit the IPP site.
- > Click through the certificate error
- > Click the "Certificate Error" button in the address bar.
- > Click View Certificate
- > Click Install Certificate
- > Click the "Place all certificates in the following store" radio button, and choose the "Trusted Root Certification Authorities" store. If you don't do this, the certificate goes in your personal store, and it isn't trusted by IE.

- Enter the Login and Password

4.1.3 Power Source View

From the **Views** menu Item, select the **Power Source** item:

You will be able:

- to supervise the information from the UPS that powers the Intelligent Power® Protector computer
- to drag and drop the panels in this window

The screenshot displays the Eaton Intelligent Power Protector web interface. The top navigation bar includes the Eaton logo and the text "Intelligent Power® Protector". On the right of the bar, there are links for "Logout 'admin'" and "Help".

The main interface is divided into several sections:

- Views (Left Panel):** A tree view showing "Views", "Power Source", "Events", "Settings", "Auto Discovery", "Actions", "Shutdown", "System", "Log", and "User List".
- Information and Status (Main Panel):** Displays details for the power source IP 166.99.224.119. It includes a description "Evolution 650", nominal apparent power of 650 VA, IP address, MAC address (00:20:85:FD:76:08), serial number (AV0J1901H), and location (1A09). It also shows battery state (Charging), power source (On utility), load level (28%), and battery capacity (100%).
- Measures (Right Panel):** A table of real-time measurements:

Input frequency	50 Hz
Input voltage	233 V
Output frequency	50 Hz
Output voltage	233 V
Output current	0 A
Global apparent power	161 VA
Global active power	121 W
Battery output voltage	13 V
- Environment (Right Panel):** A section for environmental data, currently empty.
- Statistics - 7 days (Middle Panel):** A summary of system status over the last 7 days, showing "On" for Master output, Maitre, and Load segments #1 and #2.
- Graph - 2 hours (Bottom Panel):** A line graph showing power source status over a 2-hour period from 06/03/10 10:11:30 am to 12:11:30 pm.
- Synoptic Diagram (Right Panel):** A schematic diagram of the Line Interactive UPS system, showing connections to Master output, Load segment #1, and Load segment #2.
- Events (Bottom Panel):** A section for recent events, currently empty.

The status bar at the bottom provides a summary of system health: OK: 13, Warning: 2, Critical: 4, Unknown: 12. The last event is noted as "05/31/10 - 8:05:43 am - 166.99.224.43 - End of UPS shutdown imminent alarm".

4.2 Panels list:

4.2.1 Information and status

This panel displays information on the device that powers the server running IPP.

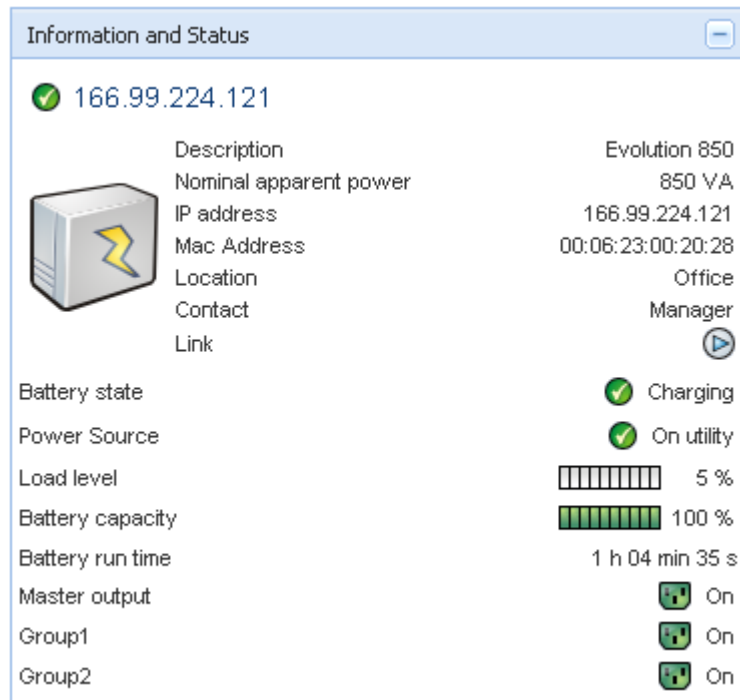

Information Panel

The following node information is displayed in this panel:

- 166.99.224.121 the DNS name (or IP address) is displayed near the “status icon”
- Description the commercial product name
- Nominal Apparent Power the UPS Nominal Apparent Power (in VA or KVA)
- IP address (if network acquisition) the Web/SNMP card IP address
- Mac address (if network acquisition) the Web/SNMP card Mac address
- Location the device location (value of syslocation object or can also be configured in the Device page)
- Contact the device contact (value of syscontact object or can also be configured in the Device page)
- Serial Number The device Serial Number (if available)
- Link link to the device Web site (if available)
- Battery state Charging / Discharging / Default / Floating / Resting
- Power source AC Power / Battery
- Load Level the output load level of the device
- Battery capacity Battery capacity of the device
- Battery run time the device remaining backup time
- Master Output Main output status (ON/OFF/Internal Failure/On Automatic Bypass/Manual By Pass/Overload)
- Group #x output outlet status (ON/OFF)

Note: The information displayed in this panel depends on the UPS capabilities.

4.2.2 Measures

Measures			
Input frequency			50 Hz
Output frequency			1.4 Hz
Input voltage	238 V	238 V	238 V
Input current	6 A	5 A	5 A
Output voltage	238	238	239
Output current	2 A	0 A	0 A

This panel displays the selected device electrical parameters (single phase or 3 phase) depending on the node capabilities.

4.2.3 Environment

Environment		
Temperature		22.9 °C
Humidity		18.2 %
Input #1		Open
Input #2		Open

This panel displays the selected device sensor information: Temperature, Humidity level, Dry contact status (Open/Closed)

- Temperature Sensor temperature (in °C)
- Humidity Humidity level
- Input #1 Status of first contact (open / closed)
- Input #2 Status of second contact (open / closed)

4.2.4 Graph



This panel displays the graph of the main measures of the selected device.

To read the values, proceed as follows: Place your mouse cursor over the graph, a vertical line appears over it and you can read the values in the box for the selected date.

The  button allows you to zoom in the graph.

The  button allows you to select the data you want to display in the graph (refer to following screenshot)

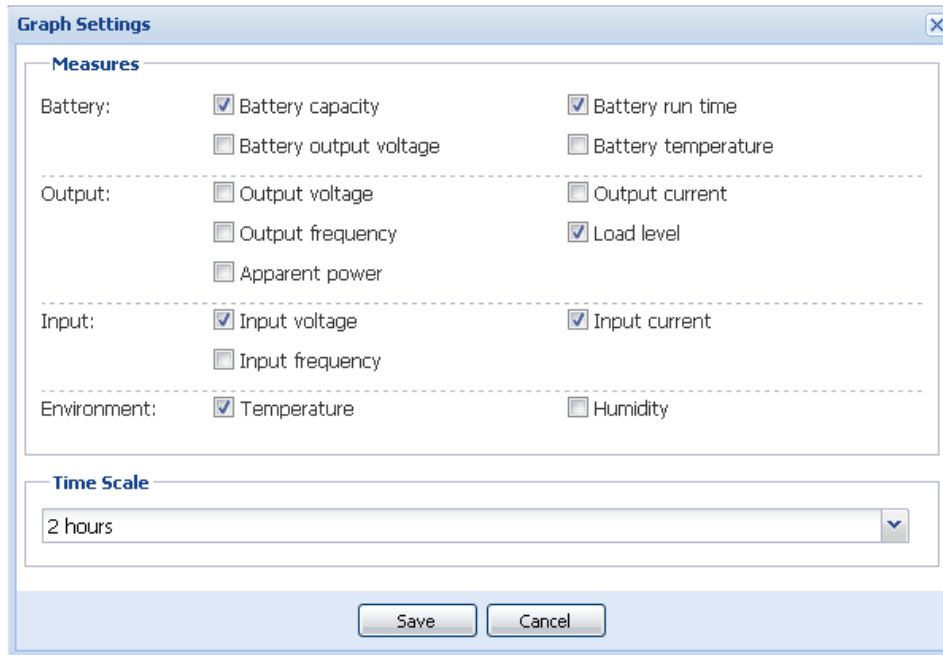

In this window, you can select up to 6 measures simultaneously

Time scale possible values are 1 hour / 2 hours / 6 hours / 12 hours / 24 hours / 2 days / 1 week

4.2.5 Synoptic

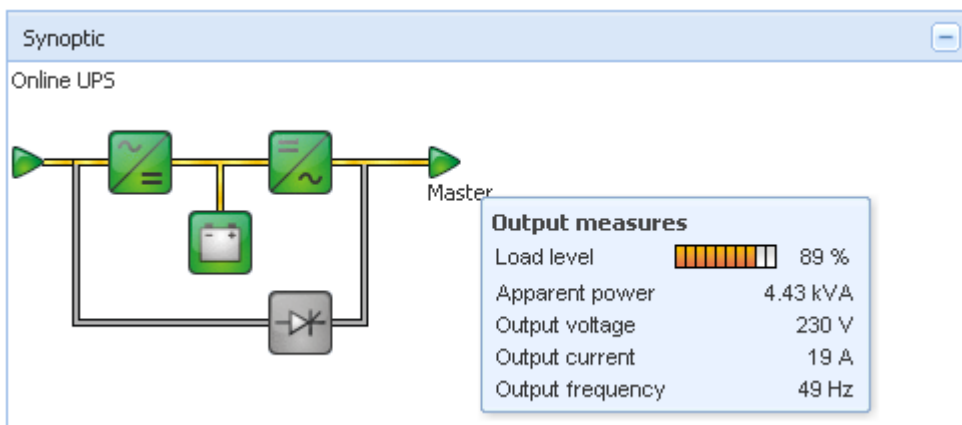









This panel displays the selected device synoptic.

In the top left corner, the UPS electrical topology is indicated (Online UPS, Line Interactive UPS, ...).





A tooltip is displayed when the mouse is over one of the functional block.

Synoptic Color codes:



- UPS modules:

AC/DC	DC/AC	By-Pass	Colour	Description
			Green	Status OK & Active
			Red	Internal fault & Inactive
			Grey	Status OK & Inactive or Unknown



- Battery module:

Symbol	Colour	Description
	Green	Status OK
	Orange	Battery charge is less than 50%
	Red	Battery fault or End-of-backup
	Grey	Battery status unknown



- Electrical flows:

Symbol	Colour	Description
	Yellow	Current flow through the cable Note: the object animation gives the direction of current flow
	Grey	No current flow through the cable (Warning the cable may be under voltage)

- Electrical power source at UPS input:

Symbol	Colour	Description
	Green	Source powered. Status OK
	Grey	Source not powered or status unknown

Examples of combinations between flow status and power source status:

	Green/ Yellow	The electrical power source is powered and provides electrical flow
	Green/ Grey	The electrical power source is powered and does not provide electrical flow

- Load at UPS output: (its status is linked to that of the UPS output status)

Symbol	Colour	Description
	Green	Load powered and protected. Status OK
	Red	Load not powered
	Grey	Load status unknown

Examples of combinations between flow status and load status:

	Yellow/ Green	Load powered and protected
	Grey/ Red	Load not powered

4.2.6 Events

Status	Date	Message
	27/01/09-15:59:22	Bypass : Return on UPS
	27/01/09-15:58:45	Output on automatic bypass
	27/01/09-15:58:43	The outlet group 2 is on
	27/01/09-15:58:42	The outlet group 1 is on
	27/01/09-15:58:40	The UPS output is on
	27/01/09-15:58:32	The UPS output is off

This panel displays the events list of the selected node. You can sort the events according to Status, Date, and Message by clicking on the column header.

4.2.7 Statistics

Statistics - 7 days	
Communication between card and device lost	4
The UPS output is off	4
Network communication with device lost	3
Estimated consumption	27.54 kVA.h
Power lost count	3
Cumulated power lost time	6 min 42 s
UPS fault	3
UPS overload	1

02/17/09 - 12:00:00 am 02/23/09 - 11:59:59 pm

This panel displays the statistics of the selected node.

The button allows you to select the time interval for the statistics.

You can adjust the time interval by clicking on the 2 buttons with the “From” and “To” dates.

Here is the list of Statistics Computed Data:

- Apparent Consumption (or Active Consumption in next release)
- Average Apparent Power (or Average Active Power in next release)
- Power Failure Count
- Power Failure Cumulated Duration
- Battery Fault Count
- Internal Failure Count
- Overload Count
- Warning Alarm Count
- Critical Alarm Count
- Output Off Count
- Communication Lost Count

Note: This information depends on device capabilities

4.3 Events

4.3.1 List representation

Select the **Events** -> **Events List** and the following page appears:

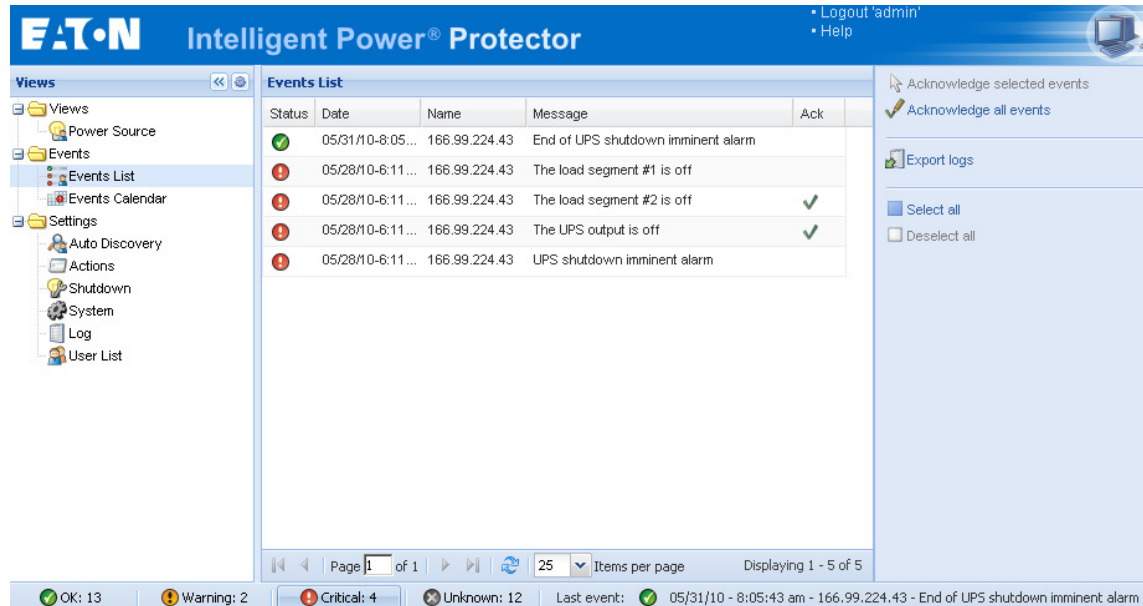

Alarms list.

Buttons on the bottom toolbar allow filtering on unacknowledged alarms of the corresponding level.

All new alarms are stored in this log.

You can sort the alarms according to **Status, Date, Name, Message and Ack.**

The following functions are available:

Acknowledge selected events will add a check box in the **Ack** column for selected events

Acknowledge all events will add a check box in the **Ack** column for all events

Note: When an alarm is acknowledged, it is marked with a checkbox but it is still viewable in this Event list
 It decreases the number of non acknowledged alarms at the bottom of the Web page
 The acknowledged alarms disappear in the PowerSource -> Event panel

Export Logs will create a logs.csv file with the following syntax:

```
"Date";"Node";"Type";"Level";"Object";"Value";"Message";
"2009/01/27-18:35:20.840";"166.99.250.83";"Measure";"0";"UPS.PowerConverter.Input[1].Frequency";"49";"";
```

Select all will select all displayed events

Deselect all will deselect all selected events

Tips:

You can select one alarm by clicking on it

You can select several alarms with Shift Click or Alt click

Then the selected lines appear in dark blue

4.3.2 Calendar representation

Select the **Events** -> **Events Calendar** and the following page appears:

In this matrix representation, each line is a week and each column is a day in the week.

If you select a day or an interval (with datepicker or shift+click command), events and statistics panels will give you all information for this selection and will automatically refresh when new statistics have been computed.

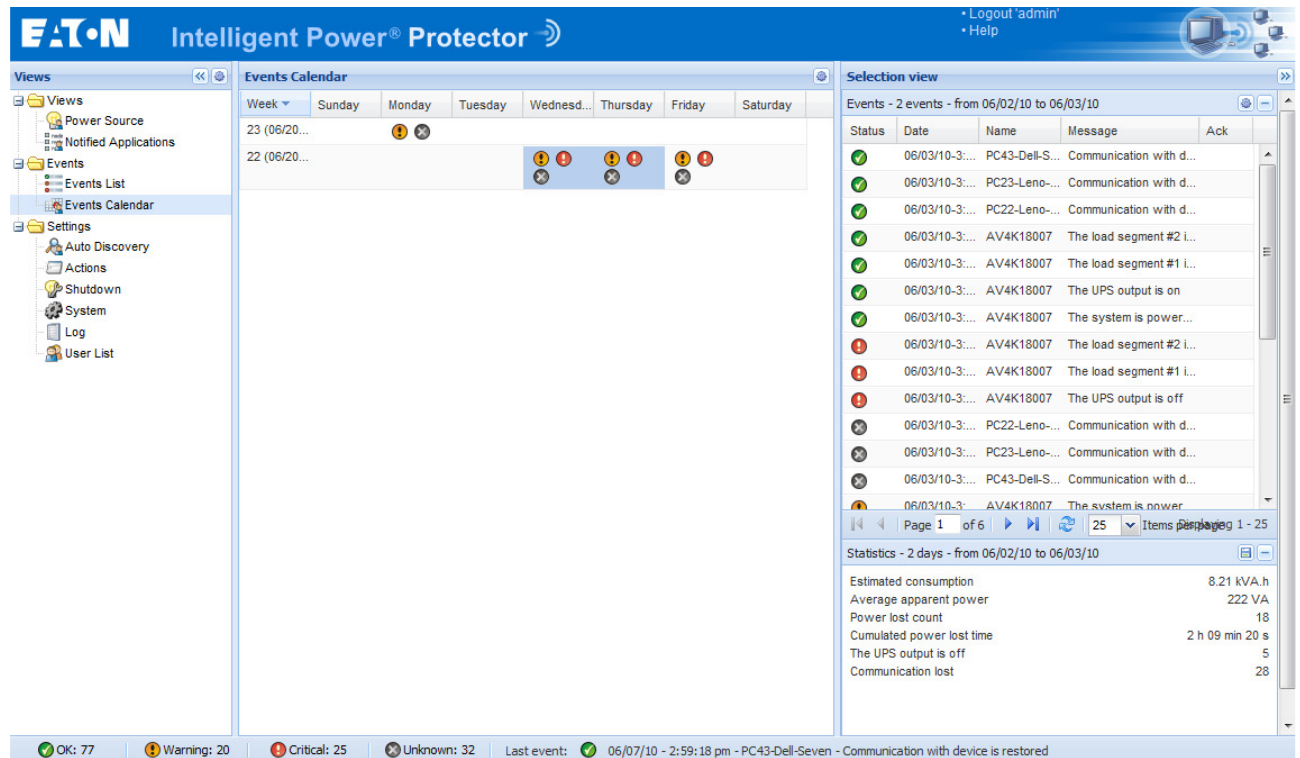

4.3.3 Nodes Events list

The icons in the different views represent the event severity.

Icon	Event status
------	--------------



Normal. With this event, the UPS device is coming back to a normal status.

Event list list (UPSs):

- Communication with device is restored
- Communication restored with UPS
- The system is powered by the utility
- The UPS output is on
- Communication restored with UPS
- Battery OK
- UPS returns to normal load
- UPS OK
- Bypass : Return on UPS
- End of low battery alarm
- The outlet group 1 is on
- The outlet group 2 is on
- Communication failure with environment sensor

-
- Communication restored with environment sensor
 - Humidity is in normal range
 - Temperature is in normal range
 - Input #x on
 - Input #x off
 - End of warning alarm
 - End of critical alarm
 - Redundancy restored
 - Protection restored



Warning. A problem occurred on the UPS device. Your application is still protected.

Event list list (UPSs):

- The system is powered by the UPS battery
- Output on automatic bypass
- Output on manual bypass
- Humidity is below low threshold
- Humidity is above high threshold
- Temperature is below low threshold
- Temperature is above high threshold
- Warning Alarm *(a generic Warning alarm is active on the device)*
- The device is under its load alarm threshold
- The device is over its load alarm threshold
- Protection lost
- Redundancy lost
- Shutdown in {time}



Critical. A serious problem occurred on the UPS device. This problem requires an urgent action. Your application might NOT BE powered anymore.

Event list list (UPSs):

- The UPS output is off
- The outlet group 1 is off
- The outlet group 2 is off
- Battery fault
- UPS overload
- UPS fault
- Low battery alarm
- Applications must stop immediately...
- System shutdown in progress...
- Critical alarm *(a generic Critical alarm is active on the device)*





Communication lost

Event list:

- The communication with the server has been lost
- Communication with UPS device has failed

4.4 Launching Device Web interface

From the **Status** panel, you can access the Web Page for Eaton cards including an on-board web server. Click on the web **Link** associated to this blue icon  (http access) or this yellow one  (https access).

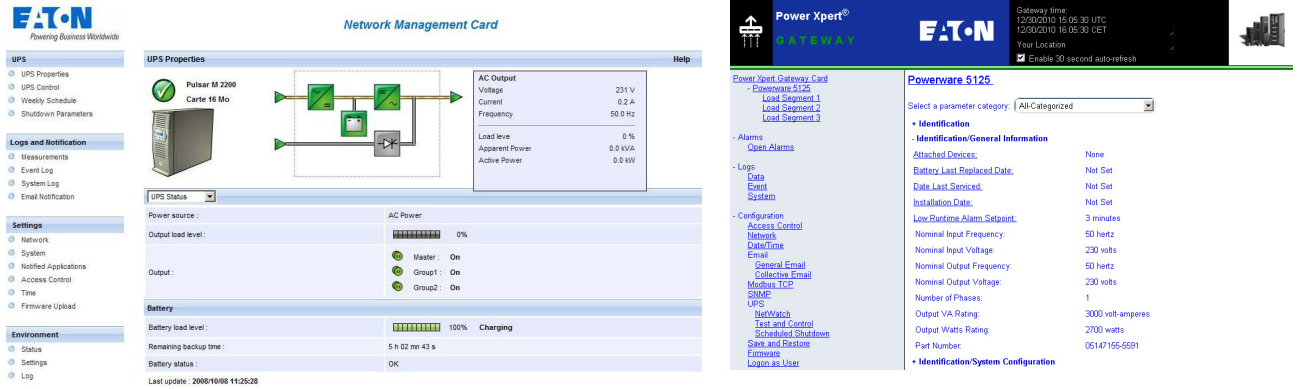

The left screenshot shows the 'Network Management Card' interface for a Pulsar M 2200 UPS. It features a navigation menu on the left with sections like 'UPS', 'Logs and Notification', 'Settings', and 'Environment'. The main area displays 'UPS Properties' with a status indicator, a diagram of the UPS system, and 'AC Output' details: Voltage (231 V), Current (0.2 A), Frequency (50.0 Hz), Load level (0%), Apparent Power (0.0 kVA), and Active Power (0.0 kW). Below this, 'UPS Status' shows 'Power source: AC Power', 'Output load level: 0%', and 'Battery' status at 100% charging with a remaining backup time of 5 h 02 m 43 s.

The right screenshot shows the 'Power Xpert' interface for a Powerware 5125. It includes a navigation menu on the left with sections like 'Power Xpert Gateway Card', 'Alarms', 'Logs', 'Configuration', and 'UPS'. The main area displays 'Powerware 5125' system information, including 'Gateway time' (12/30/2010 16:05:30 UTC) and 'Your Location'. A dropdown menu allows selecting a parameter category. The 'Identification/General Information' section lists various system parameters such as 'Attached Devices', 'Battery Last Replaced Date', 'Date Last Serviced', 'Installation Date', 'Low Runtime Alarm Setpoint', 'Nominal Input Frequency', 'Nominal Input Voltage', 'Nominal Output Frequency', 'Nominal Output Voltage', 'Number of Phases', 'Output VA Rating', 'Output Watts Rating', and 'Part Number'.

Opening different Web interfaces from Intelligent Power[®] Protector.

5 Advanced Management

The Intelligent Power[®] Manager (1.12 minimum release) can **remotely**:

- Display an Intelligent Power[®] Protector configuration.
- Configure a single Intelligent Power[®] Protector.
- Synchronize multiple Intelligent Power[®] Protector configurations.
- trigger the Intelligent Power[®] Protector Upgrade

More details are available in Intelligent Power[®] Manager user's manual. (You can evaluate the free version to manage up to 10 nodes from <http://powerquality.eaton.com>)

6 Compatibility List

Eaton has tested the compatibility of Eaton Power Protector with the following devices and applications:







6.1 Eaton Serial line Devices

Eaton Equipment designation	Connectivity
Eaton Powerware series: 3105, 5110, 5115, 5130, 9130, 9135, 9140 and legacy 9120, 9125	USB or RS232
Eaton Powerware series: BladeUPS, 5125, 9155, 9355, 9390, 9395	RS232 only
Eaton Pulsar Series: Eaton 5PX Evolution 650 / 850 / 1150 / S 1250 / 1550 / S 1750 / 2000 / S 2500 / S 3000 Pulsar 700 / 1000 / 1500 / 1000 RT2U / 1500 RT2U (intl. & US Models) Pulsar M / EX Pulsar MX & Pulsar MX Frame 16 U / MX	USB or RS232
Eaton Pulsar Series: EX RT Comet EX RT 1:1 / 3:1 / EX 5 RT (Asia/Pacific)	RS232 only

Notes:

- XSlot-USB Module for Powerware series is unsupported by Intelligent Power® Protector 1.10
- Ellipse ASR 600/750/1000/1500 USBS, Ellipse MAX, Protection Station, Protection Center, NOVA AVR, are currently supported by Personal Solution Pac software.

6.2 Eaton Network Devices

Eaton equipment designation	Type	Illustration
Network Management Card MiniSlot SNMP/Web – P/N 66102 (DA firmware revision and above) And associated Environment Sensor	UPS Option Card Eaton Pulsar	
Network Management Card & Modbus/JBus – P/N 66103 (through Ethernet Network) And associated Environment Sensor 66846	UPS Option Card Eaton Pulsar	
ConnectUPS-MS MiniSlot Network Management Card P/N 103006826 And associated Environment Sensor	UPS Option Card Eaton Powerware	
ConnectUPS-BD Web /SNMP P/N 116750222-001 (**) And associated Environment Sensor	UPS Option Card Eaton Powerware	
ConnectUPS-XSlot Web /SNMP/xHubCard, P/N 116750221-001 (*) (**) And associated Environment Sensor	UPS Option Card Eaton Powerware	
PXGX2000 P/N 103005868-5591 (*) (***)	UPS Option Card Eaton Powerware	

Note: Connect-UPS-E for Powerware series should be compatible, but Eaton didn't perform official testing on it.

(* *With Intelligent Power Protector 1.10, the Eaton Powerware 3 phase UPSs compatibility is officially available according to the following solution:*

- **Cards:** ConnectUPS-X v4.32 or PXGX2000 v1.4.2.1
- **UPSs:** Blade UPS, PW9155 Dual Phase, PW9355 10-30 kVA, PW9390 40-160 kVA, PW9395 225-1100 kVA & SBM
- **Known limitation:** PW9315 will not be supported by this 1.10 release.

(**)Required Connect UPS XSlot/BD configuration:



- ⇒ Set the IPP discovery password to the same value as the Web /SNMP read community name (default is public)
- ⇒ In ConnectUPS Write Access Managers control menu (via telnet, ssh or serial connection): disable SNMP access restricted by IP/Hostname (this is the default setting since firmware version 2.02) or configure it correctly (IPP has to be configured in trusted host list)

(***)Required PXGX 2000 configurations:

- ⇒ Set the IPP discovery password to the same value as the PXGX2000 read community name (default is public)
- ⇒ In PXGX2000 Access control page: disable SNMP access restricted by IP/Hostname or configure it correctly (IPP has to be configured in trusted host list)
- ⇒ In PXGX2000 Take care to configure PXGX2000 in SNMP V1 or SNMP V1 + V3

6.3 Eaton Legacy cards

These cards should be compatible, but Eaton didn't perform official testing on them.

Eaton equipment designation	Type	Illustration
MGE Network Management Card MiniSlot SNMP/Web – 66244 And associated Environment Sensor	UPS Option Card (legacy)	
Network Management Card Transverse SNMP/Web – 66074 And associated Environment Sensor	UPS Option Card (Legacy)	

7 FAQ and Error messages

In the HTML pages:

Cannot display the UPS properties page. HTTP 404 error with IE.

Solution: Check the URL entered.

> <https://<name or IP of the computer hosting IPP>:4680/>

or

> <http://<name or IP of the computer hosting IPP>:4679/>

In the Linux Graphical System integration:

Linux (Debian and Ubuntu, with Gnome)

Eaton-Intelligent Power Manager - "Open" shortcut is not present

Solution: The menu shortcut will appear the next time you will launch Gnome.

In the meantime, simply open a web browser and enter the following URL: <http://localhost:4679/>

Linux (OpenSuSe 11, with KDE)

Eaton-Intelligent Power Manager - "Open" shortcut is not visible

Solution: To find IPP icon, use the 'Search' function from the Application Menu.

You should then find IPP icon in the Favourites section.

Linux (Red Hat, OpenSuSe and Mandriva)

Notification icon ("system tray icon") is not started upon installation or upgrade

Solution 1:

Launch the following command, as your standard user, from a terminal or using a "Launch" feature:

```
$ /usr/local/Eaton/IntelligentPowerProtector/mc2 -systray
```

Note that if you launch this command from a terminal, you will need to add an ampersand (" &") at the end of the command line, in order to detach the process.

Solution 2:

Close your graphical session, and log into a new one.

The notification icon will be automatically started with the new graphical session.

In the Linux Network System integration:

Linux: Network proxy not detected

If your network proxy was not detected during installation, you will not be able to access automatic update and other Internet resources from IPP.

This can be validated by the absence of `proxy.cfg` under

`/usr/local/Eaton/IntelligentPowerProtector/configs/`

Solution:

Create a file name 'proxy.cfg' under /usr/local/Eaton/IntelligentPowerProtector/configs/ with the following content:

```
{  
  'proxyHost': "your.proxy.address.com",  
  'proxyPort': "proxy_port"  
}
```

For example:

```
{  
  'proxyHost': "proxy.domain.com",  
  'proxyPort': "8080"  
}
```

Then restart IPP to reload the configuration

Linux:

IPP Linux displays the Network Communication lost alarm after 20 minutes only

Solution:

Improvement in a next release

In Windows Vista Hibernate sequence:

By default IPP runs an Operating System hibernate. Unfortunately, the Hibernate option of Windows Vista is sometimes no more available after a "Disk Cleanup". In this case Windows Vista hibernate fails.

Solutions:

Change the IPP shutdown configuration from "Hibernate" to "Shutdown"

Or

Execute the command "Powercfg -h on" under an administrator account, to restore the Windows Vista hibernate option.

<http://support.microsoft.com/default.aspx?scid=kb;EN-US;928897#LetMeFixItMyself>

In shutdown sequence:

PW 9130 UPS doesn't shutoff as expected when IPP is connected through USB/Serial and when a Web SNMP card is plugged into the slot

Solution: you have to disable the UPS shutoff command from the card interface to ensure a proper shutdown of your machine protected by IPP.

For that, go to the "Configuration/UPS Shutdown and Restart Settings" page of the card and select "No" for the parameter "Load Segment to Turn Off after OS Shutdown".

Note: If you have chosen to use the USB/serial connector for communication between IPP and your UPS which also has a web card inside, it is better to disable the shutdown criteria of the card to ensure the shutdown and the restart of your machine.

8 Glossary

IP address

When TCP/IP is installed on a computer, an address is assigned to the system. Each address is unique and is made up of four numbers, each between 0 and 256 (e.g. 168.8.156.210).

NMS (Network Management System)

The NMS supervises SNMP devices connected to the TCP-IP Network.

Network Shutdown Module

The Network Shutdown Module is a software module that uses the information transmitted by the Network Management Card/Proxy to inform computer users on the current status of the electrical power supplied to the computer.

If the supply of the electrical power from the UPS is at risk, the Network Shutdown Module initiates an orderly shutdown of the computer under the most secure conditions possible.

SSL (Secure Socket Layer, created by Netscape)

A solution for securing transactions over the internet. SSL is a communication protocol that authenticates the data exchanged, as well as ensuring its confidentiality and integrity. The protocol uses a recognized encryption method, the **RSA algorithm with a public key** (where RSA means Rivest, Shamir and Adleman, the inventors). An RSA key is the result of operations involving prime numbers. SSL is built into the Internet browsers on the market. The padlock in the bottom of your browser screen is automatically displayed if the server sending information uses SSL.

TCP/IP (Transmission Control Protocol / Internet Protocol)

Family of protocols for the transport and network layers.

9 Acknowledgements

Huge thanks from the Eaton software development team to the following projects:

Spider Monkey

JSMiniNSPR

Ext JS

SQLite

the SQLite Project <http://www.sqlite.org/>.

Their generous donation of the source code to the public domain helped us for this project.

Open SSL

- This IPP product includes software developed by the OpenSSL Project for use in the OpenSSL Toolkit (<http://www.openssl.org/>)”
- This IPP product includes cryptographic software written by Eric Young (ey@cryptsoft.com)
- This IPP product includes software written by Tim Hudson (tjh@cryptsoft.com)

Lib USB

Net SNMP

The full License version for each of these projects is available from Intelligent Power Protector (Settings -> System -> About)