

## S-10 Station Message Detail Recording (SMDR)

### General Description

This feature provides a call record for all outgoing Station to Trunk Calls and Incoming Trunk to Station Calls. When the system is equipped with this feature, an RS232C output port or a SOCKET interface (LAN) is provided, permitting interface with a customer-owned computer system. All output is in the ASCII format, and includes the following:

- Calling Telephone Number
- Dialed Number (maximum of 24 digits)
- Route Number
- Start of call time
- Disconnect time
- Year, month and date
- Condition (Attendant handled, transfer, etc.)
- ACCOUNT CODE [A-18] (10 digits maximum)
- AUTHORIZATION CODE [A-28] (10 digits maximum)
- FORCED ACCOUNT CODE [F-7]

#### [Additional FCCS Format]

- Called Party Type (Attendant Console/Station)
- Call Start/Call end time (millisecond)
- Call metering
- FPC/User Group/Telephone Number (Calling Party)
- FPC/User Group/Telephone Number (Called Party)
- FPC of the node providing the route for the call
- Logical Route Number
- FPC of the node providing the first-choice route
- First-choice Logical Route Number
- Trunk arrival time and Abandoned Call Information (only for Incoming Call)

#### [Station-to-Station Basis SMDR]

SMDR can be output for Station-to-Station Calls by assigning data.

#### [SMDR by MA-ID via IP Network]

Multi Area ID (MA-ID) can be assigned on a network basis for identifying the location. Then, SMDR can be output for calls over IP network when MA-ID of both parties are not identical. For more information, see SMDR MULTI AREA ID VIA IP [S-144].

#### [SMDR - Multiple Time Zone]

SMDR output that takes into account time difference when a call is made over different time zones is available. For more information, see [M-114] MULTIPLE TIME ZONE.

**Note:** *SMDR (Station Message Detail Record) collectively means billing information and service. When connecting to SMDR system, simultaneous use of LAN and RS-232C connection is not available in a single node.*

## Operating Procedure

No manual operation is required. Call record outputs are produced automatically.

## Service Conditions

- **RS232C Interface Conditions:**
  1. When you use the SMDR system with a RS-232C interface, be aware of the following:
    - When connecting to the SMDR system, simultaneous use of LAN and RS-232C connection is not available in a single node.
    - When you change the interface for the SMRD system (from RS-232C to LAN and vice versa), all the data collected in the Telephony Server is erased. Therefore, before performing such operation, output all the collected data to the SMDR system.
  2. SMDR information facilitates analysis of Trunk traffic and can be readily applied for cost allocation or billing purposes.
  3. SMDR may be programmed to record either all Outgoing Calls or only Toll Calls, depending upon user requirements.
  4. Both Incomplete and Abandoned Calls will be discarded by the SMDR.
  5. When ROUTE ADVANCE [R-6] or LEAST COST ROUTING (LCR) - 3/6-DIGIT [L-5] is provided with the system, SMDR will record the Route Number selected.
  6. The maximum number of digits dialed cannot exceed 24.
  7. When customer-owned computer equipment is connected via RS232C interface, SMDR information will be transmitted directly to the computer as each call record is completed.
  8. If the Outgoing Call is directed to a Trunk that cannot give Answer Supervision from the Central Office, the start of call time is 18 seconds after the last digit is dialed. This timer value is set on the System Data.
  9. If the distance between the system and the processing computer exceeds 50 feet (15 meters), an asynchronous modem should be used.

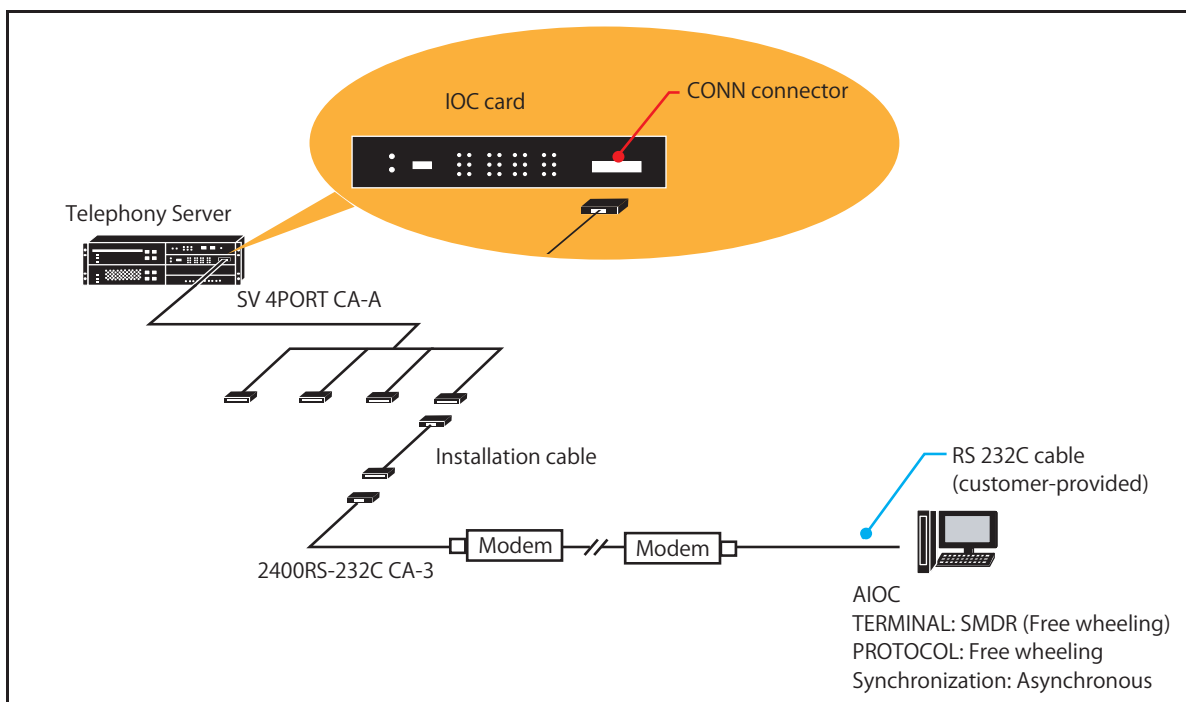

## S-10 Station Message Detail Recording (SMDR)

---

10. RS232C Interface specifications:

Synchronization	Asynchronous
Data Speed	300, 600, 1200, 2400, 4800, 9600bps
Code	ASCII 7-Bit + parity Bit
Maximum Distance	50 ft. (15m) without modem
11. Supervision on the status of the external RS232C terminal is not performed.
12. FORCED ACCOUNT CODE [F-7] can be recorded on SMDR, for INWATS and Central Office Incoming Calls, when used in conjunction with the REMOTE ACCESS TO SYSTEM [R-2] feature.
13. FORCED ACCOUNT CODE [F-7] cannot be registered on SMDR if the Incoming REMOTE ACCESS TO SYSTEM [R-2] Calls are terminated to Stations via night service or DID [D-8].
14. For REMOTE ACCESS TO SYSTEM [R-2] Tandem Connections, the FORCED ACCOUNT CODE [F-7] is registered for Outgoing Trunks only.
15. The PBX can accommodate up to 7 active ports or 4 redundant ports. Additional hardware is required.
16. AUTHORIZATION CODE [A-20] can be recorded on SMDR.
17. The maximum number of simultaneous calls can be stored in the system memory (active calls) is 47,000. When a call is completed, the record is sent to the output device and is removed from memory.
18. If an overflow occurs, calls are allowed to complete and are not recorded.
19. ATTENDANT-CONTROLLED CONFERENCE [A-2]: If the Attendant adds a Trunk to the Conference, the Attendant Conference line terminal is recorded.
20. LEAST COST ROUTING - 3/6-DIGIT [L-5]: The Calling Party can dial an ACCOUNT CODE [A-18] before the LCR Access Code. The Called Number is recorded (as modified for sending).
21. If an ACCOUNT CODE [A-18] is dialed, the maximum digits of the Called Number is 22.
22. CENTRALIZED ATTENDANT SERVICE (CAS) [C-20]: The SMDR record is provided for calls extended outward by a CAS Attendant.
23. DIRECT INWARD DIALING (DID) Trunk Calls [D-8]: If the call is to the Attendant, the Attendant can input an ACCOUNT CODE [A-18] before extending the call.
24. INDIVIDUAL Trunk Access [I-4]: The Attendant cannot dial in an SMDR account Code before using direct Trunk selection.
25. Incoming TIE Trunk Calls: If an Incoming Call to the Attendant is extended, the Attendant can input an ACCOUNT CODE [A-18].
26. SERIAL CALL [S-15]: The duration of the total call is recorded on the last Station Call.
27. STATION HUNTING [S-7, 8, 9]: The hunted-to Station is recorded in the Called Number field.
28. TANDEM TIE TRUNK [T-1] Calls: The Calling Number is the Incoming Trunk Route plus Trunk Number; the Called Number is the number dialed.
29. UNIFORM CALL DISTRIBUTION (UCD) [U-1]: The Calling Number is the Incoming Trunk Route plus Trunk Number. If the call is to a Station, the Station answering the number is recorded as the Dialed Number.
30. On an Incoming Trunk Call to the Attendant, the Attendant Call record will start upon answering and complete when the Attendant releases. A Station Call record will start when the Attendant releases and complete when the Station goes on-hook. If required, a Station record will not be generated if the Station does not answer.
31. A system option is available to allow or restrict call completion in the case where a failure occurs in transmitting SMDR data from the processor to the I/O port.

## S-10 Station Message Detail Recording (SMDR)

32. Additional hardware is required.

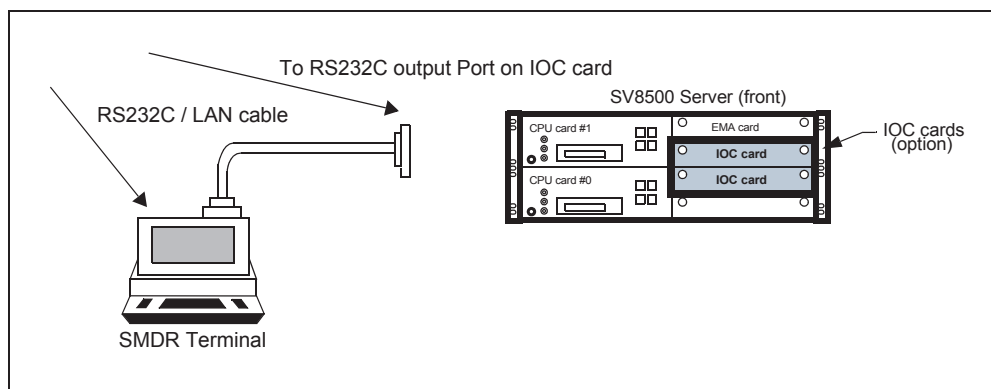

33. When either of the 2 parties goes On-Hook (or presses Transfer Key, Hold Key, Answer Key, Over Key) during Station-to-Station Calling [S-11], output of the billing information will be completed.
34. In a CCIS environment if a node has a PHC and IPTRK coexisting that node cannot be the centralize point for call accounting.
35. SMDR data can be output via LAN cable.
36. A maximum of four SMDR apparatuses per node are available.
37. It is normal operation that ACC and ANI data is sent to SMDR if ACNP is assigned.
38. The LAN and RS232C interfaces cannot be used simultaneously for connecting SMDR equipment in the same node.

### • Relocation condition for SMDR:

When relocating SMDR equipment to another node, reassign the billing information-related data. The relocation conditions are shown below.

1. Make sure there is no billing information in the each node from the Center Node before changing the SMDR location. (make sure billing information is output to the SMDR by sending test signal.)
2. Exact billing information may not be output to SMDR while changing the SMDR location.
3. When removing the SMDR equipment from the Center Node, first delete all of the billing information-related data, and also when connecting the SMDR to new-Center Node, the user must, first of all, assign appropriate billing information-related data.
4. Assign the Fusion Point Code (FPC) of the new-Center Node to all node including the previous Center Node by ASYDL (System Data 1 Index 577).

### • FCCS Conditions:

1. Call Time specification:
  - The base for Call Start Time and Call End Time is the time in the Calling Party-side node.
  - In case there is time difference between each node, related time difference data, based on the UCT (Universal Coordinated Time) standard, should be written in Network Data Memory (NDM) by using the ATDF command.
  - Because billing information gathering is performed in the Called Party-side node, the Call Start Time in the originating node is determined in a way the deduction of time between Calling and Called Party nodes is added or subtracted to/from the Called Party-side time. (If there is no time difference data in any [both] of the nodes, the Call Start Time is specified automatically by that in the Called Party-side node.)

## S-10 Station Message Detail Recording (SMDR)

---

- A counter, not the clock providing the current time, is used for Call End Time calculation. The calculation method is as follows:
  - a.) Call Start Time (by using the clock) and the current counter value are registered to the Call Base Table, soon after a Line Connection is established.
  - b.) Upon the call completion, the deduction between the counter value shown in a.) and that renewed during the call exchange is calculated.
  - c.) The deduction is transformed to a time (hour, minute, second, millisecond) format.
  - d.) The transformed time is added to the Call Start Time registered in a.)-End.
    - The counter-based time is renewed in every 16.384 milliseconds.
- 2. The maximum number of calls available for concurrent storage in the system memory (active calls) is:

System Type	Maximum Buffer Capacity for Storing SMDR
IMG/MMG system	47,000 calls / System
UMG system	47,000 calls / 1 LMG

**Note:** The same buffer memory is used for storing Centralized Billing data and Billing of calls that are made in the center node.

**Note:** The upper limit of polling buffer rate can be specified by ASYDL, SYS 1, Index 586. When the value has not been set, default 00 (Hex) = 50% will be applied.

3. When the center node stores the billing information of calls that are made in itself, the center node checks the number of completed calls in all nodes on a CCIS/FCCS network including itself. The system message “6-O (SMDR Output Buffer Overflow Alarm message)” and “6-P (SMDR Output Buffer Overflow Release)” are issued if SMDR output buffer in the center node is in the following conditions:

“6-O” is issued when:

- SMDR output buffer is not overflowing, and
- SMDR output buffer usage rate exceeds the value assigned to ASYD, SYS1, INDEX 249.

“6-P” is issued when:

- SMDR output buffer is overflowing, and
- SMDR output buffer usage rate is less than the value assigned to ASYD, SYS1, INDEX 250.

Even if the SMDR output buffer usage rate in the center node exceeds the value assigned to ASYD, SYS1, INDEX 249 due to polling local nodes, the system message “6-O” is not issued if there are no billing information of calls made in the center node afterwards.

4. If an overflow occurs, calls are allowed to complete but are not recorded.
5. To output the FCCS-related billing data, the external SMDR terminal should be compatible also with the IMX text format patterns.
6. When a Station originates an outgoing Trunk Call using a Trunk in the Remote Node (the Station and the Trunk belong to an FCCS Network), the billing information for the Station to Trunk Connection is not recorded.
7. Because the FCCS Service achieves a completely fused link between multiple distant nodes, Intra-Station Connections and Node-to-Node Connections are theoretically considered identical.
8. When a Line Connection is established on the FCCS, the billing data concerned is collected fully in the Called Station-side node, not in the Calling Station side. The collected data is then transmitted to the SMDR terminal as the call finishes.

## S-10 Station Message Detail Recording (SMDR)

---

9. Multiple Center Nodes can be assigned on a FCCS Network for centralized billing purposes.
10. Transmission of call base table with 264 bytes.
11. When the user performs system changeover (using MBR Key, CMOD command or etc.), system messages (26-V, 26-W) are displayed. However, there are no defective conditions.
12. The figures on the following pages show the Service Conditions of Polling Method and the sample data assignment, focusing on when CCIS links are involved.
13. SMDR data assignment is required for all nodes in the FCCS network when using Centralized Billing - FCCS feature. (See Example 9 for the sample data assignment.)
14. SMDR data will be stored in a node whose incoming trunks received the data.
15. When SMDR equipment is not connected to the Center Node, polling is failed from a Center Node to a Local Node. If the Center Node is a Local Node used by Centralized Billing - CCIS [C-55], polling is available.
16. After the Center Node receives billing information from a Local Node, it returns ACK to the Local Node. If the Local Node fails to receive ACK due to a network failure, the Local Node sends billing information again. Therefore the billing information is output redundantly.

## S-10 Station Message Detail Recording (SMDR)

### Example 1

- Node A (FCCS - Center Node) collects the billing information of Nodes B and C via FCCS using the polling method.

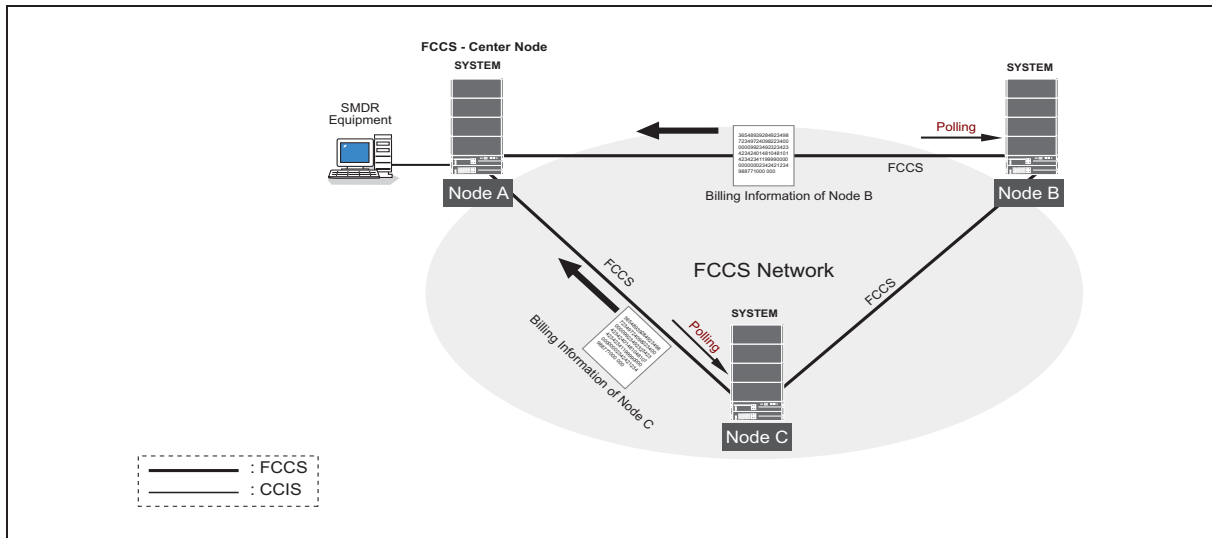

#### [Common Data]

ASYD	System Data 1	Indexes 32, 34
	System Data 2	Index 3
ASYDL	System Data 1	Index 576 b0 = 1

#### [Node A]

ASYD	System Data 1	Index 288	Assign when RS-232C output is used.
ASYDL	System Data 1	Index 576	Assign Bit 2 = 1 (when using LAN interface for SMDR)
		Index 577	Assign 00H.
		Index 578	Assign when LAN output is used.(Bit 4** of each Index)
		Index 608	Assign Node B and Node C.

**\*\* Note:** When using LAN Interface for SMDR, a TCP/IP LAN Address, Subnet Mask Address, and Gateway Address must be assigned to the Active CPU. Use either ASYDL, Sys-1, Indexes 515 through 526 to assign these addresses or the ADTM command.

#### [Node B, Node C]

ASYD	System Data 1	Indexes 288 - 295	Assign all 00H.
ASYDL	System Data 1	Index 577	Assign the FPC of Node A.
		Index 578 - 581	Assign all 00H.

## S-10 Station Message Detail Recording (SMDR)

### Example 2

- The following shows an example of Centralized Billing - CCIS when non-SV8500/SV7000/IPX/IMX is used.

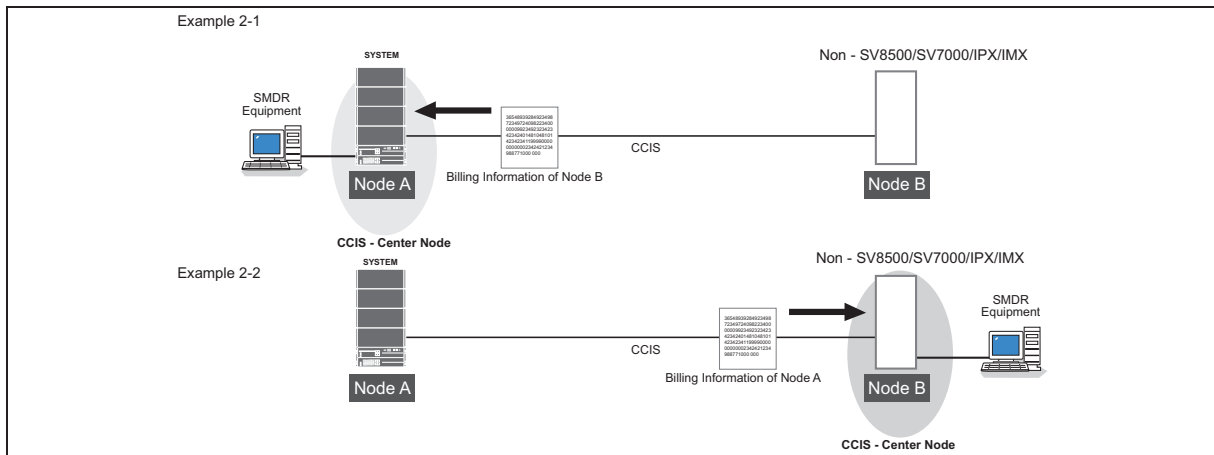

### Example 2-1

#### [Common Data]

ASYD	System Data 1	Indexes 32, 34
	System Data 2	Index 3

#### [Node A]

ASYD	System Data 1	Index 180	Assign the PC of Node A.
		Index 182	Assign 00H.
		Index 288	Assign when RS-232C output is used.
ASYDL	System Data 1	Index 576	Assign Bit 2 = 1 (when using LAN interface for SMDR)
		Index 578	Assign when LAN output is used. (Bit 4** of each Index)

**\*\* Note:** When using LAN Interface for SMDR, a TCP/IP LAN Address, Subnet Mask Address, and Gateway Address must be assigned to the Active CPU. Use either ASYDL, Sys-1, Indexes 515 through 526 to assign these addresses or the ADTM command.

#### [Node B]

ASYD	System Data 1	Index 180	Assign the PC of Node B.
		Index 182	Assign the PC of Node A.
		Indexes 288 - 295	Assign all 00H.

### Example 2-2

#### [Common Data]

ASYD	System Data 1	Indexes 32, 34
	System Data 2	Index 3

#### [Node A]

ASYD	System Data 1	Index 180	Assign the PC of Node A.
		Index 182	Assign the PC of Node B.
		Indexes 288 - 295	Assign all 00H.
ASYDL	System Data 1	Index 578	Assign all 00H.

#### [Node B]

ASYD	System Data 1	Index 180	Assign the PC of Node B.
		Indexes 288	Assign when RS-232C output is used.



## S-10 Station Message Detail Recording (SMDR)

### Example 3

The following shows an example of Centralized Billing - CCIS when SV8500/SV7000/IPX/IMX is not used.

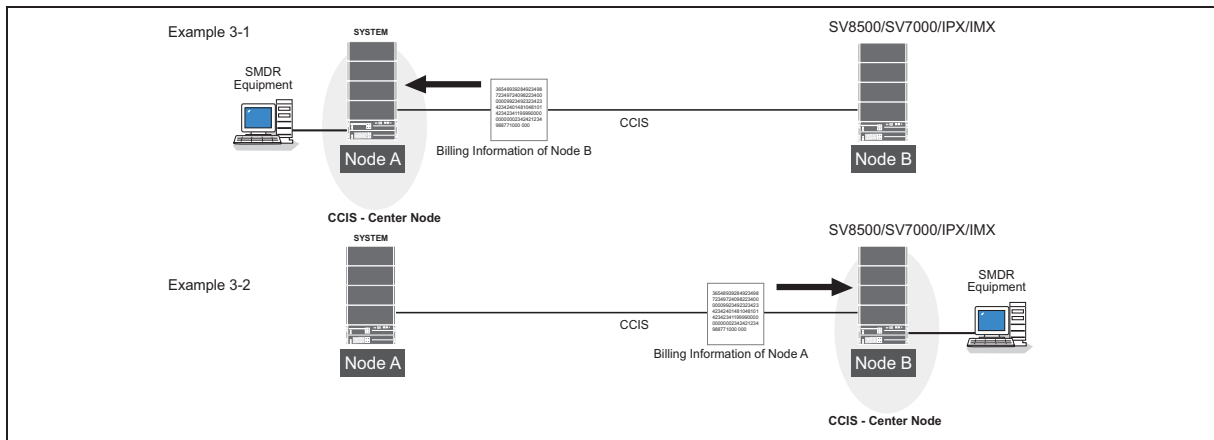

### Example 3-1

#### [Common Data]

ASYD	System Data 1	Indexes 32, 34	
	System Data 2	Index 3	
ASYDL	System Data 1	Index 576	Assign Bit 2 = 1 (when using LAN interface for SMDR)

#### [Node A]

ASYD	System Data 1	Index 180	Assign the PC of Node A.
		Index 182	Assign 00H.
		Indexes 288	Assign when RS-232C output is used.
ASYDL	System Data 1	Indexes 578	Assign when LAN output is used. (Bit 4** of each Index)

**\*\* Note:** When using LAN Interface for SMDR, a TCP/IP LAN Address, Subnet Mask Address, and Gateway Address must be assigned to the Active CPU. Use either ASYDL, Sys-1, Indexes 515 through 526 to assign these addresses or the ADTM command.

#### [Node B]

ASYD	System Data 1	Index 180	Assign the PC of Node B.
		Index 182	Assign the PC of Node A.
		Indexes 288 - 295	Assign all 00H.
ASYDL	System Data 1	Indexes 578	Assign all 00H.

### Example 3-2

#### [Common Data]

ASYD	System Data 1	Indexes 32, 34	
	System Data 2	Index 3	
ASYDL	System Data 1	Index 576	Assign Bit 2 = 1 (when using LAN interface for SMDR)

#### [Node A]

ASYD	System Data 1	Index 180	Assign the PC of Node A.
		Index 182	Assign the PC of Node B.
		Indexes 288 - 295	Assign all 00H.

## S-10 Station Message Detail Recording (SMDR)

ASYDL    System Data 1    Index 578            Assign all 00H.

[Node B]

ASYD	System Data 1	Index 180	Assign the PC of Node B.
		Index 182	Assign 00H.
		Indexes 288	Assign when RS-232C output is used.
ASYDL	System Data 1	Indexes 578	Assign when LAN output is used. (Bit 4** of each Index)

**\*\* Note:** When using LAN Interface for SMDR, a TCP/IP LAN Address, Subnet Mask Address, and Gateway Address must be assigned to the Active CPU. Use either ASYDL, Sys-1, Indexes 515 through 526 to assign these addresses or the ADTM command.

### Example 4

- Node A tries to collect the billing information of Node B and Node C via FCCS, using the polling method (Node A cannot collect the billing information of Node C via FCCS).
- Node C sends the billing information via CCIS, ignoring polling from Node A.
- Node C deletes the Point Code (CCIS) of Node A for centralized billing data when required to send billing information for polling from Node A.

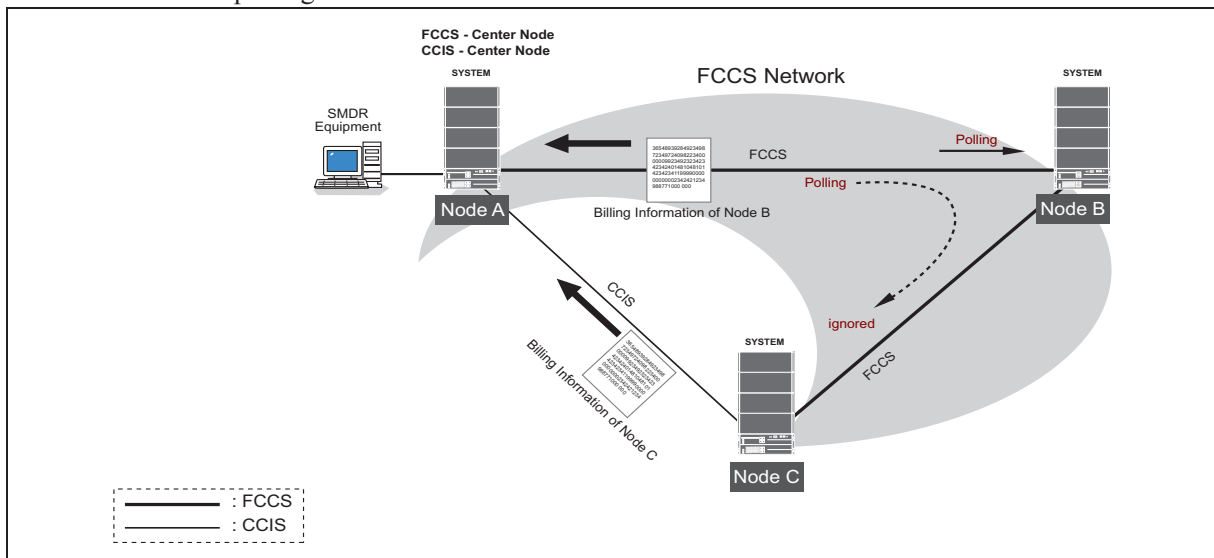

[Common Data]

ASYD	System Data 1	Indexes 32, 34
	System Data 2	Index 3

[Node A]

ASYD	System Data 1	Index 180	Assign the PC of Node A.}
		Indexes 288	Assign when RS-232C output is used.
ASYDL	System Data 1	Index 576	Assign Bit 0 for Centralized FCCS SMDR In Service.
		Index 576	Assign Bit 2 = 1 (when using LAN interface for SMDR)
		Index 577	Assign 00H.
		Indexes 578	Assign when LAN output is used. (Bit 4** of each Index)
		Index 608	Assign Node B.

**\*\* Note:** When using LAN Interface for SMDR, a TCP/IP LAN Address, Subnet Mask Address, and Gateway Address must be assigned to the Active CPU. Use either ASYDL, Sys-1, Indexes 515 through 526 to assign these addresses or the ADTM command.

## S-10 Station Message Detail Recording (SMDR)

[Node B]

ASYD	System Data 1	Indexes 288 - 295	Assign all 00H.
ASYDL	System Data 1	Index 576	Assign 01H.
		Index 577	Assign the FPC of Node A.
		Indexes 578 - 581	Assign all 00H.

[Node C]

ASYD	System Data 1	Index 180	Assign the PC of Node C.
		Index 182	Assign the PC of Node A.
		Indexes 288 - 295	Assign all 00H.
ASYDL	System Data 1	Index 576	Assign Bit 2 = 1 (when using LAN interface for SMDR)
		Index 577	Assign 00H.
		Indexes 578 - 581	Assign all 00H.

**Example 5**

- Node A tries to collect the billing information of Node B via FCCS, using the polling method (Node A cannot collect the billing information of Node B via FCCS).
- Node B sends the billing information via CCIS, ignoring polling from Node A.
- Node B deletes the Point Code (CCIS) of Node C for centralized billing data when required to send billing information for polling from Node A.

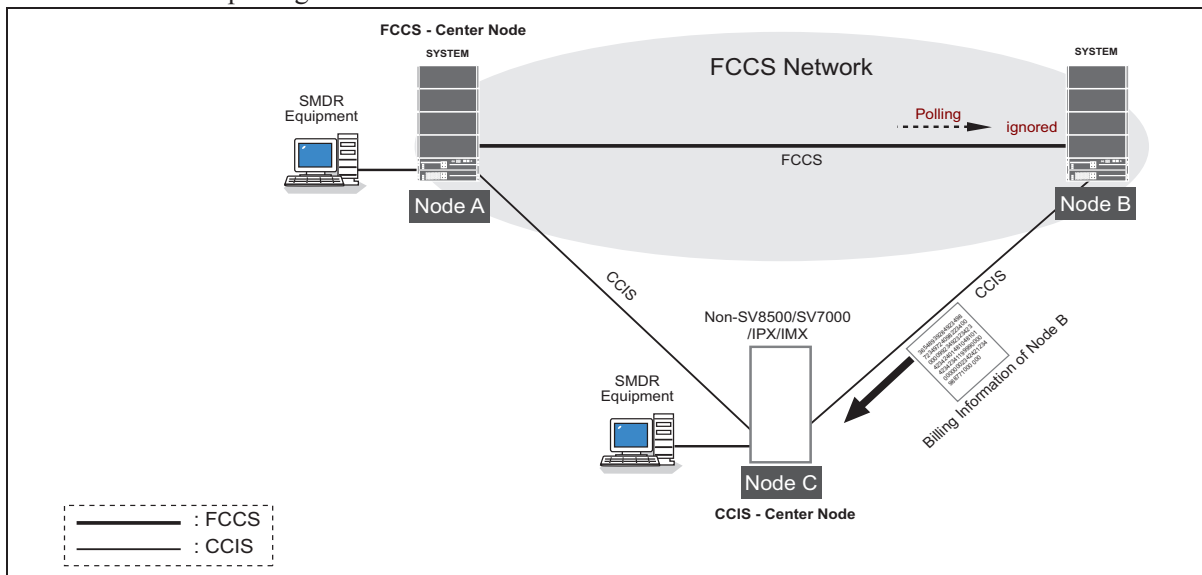

[Common Data]

ASYD	System Data 1	Indexes 32, 34	
	System Data 2	Index 3	
ASYDL	System Data 1	Index 576	Assign Bit 2 = 1, when using LAN interface for SMDR.

[Node A]

ASYD	System Data 1	Index 180	Assign the PC of Node A.
		Indexes 288	Assign when RS-232C output is used.
ASYDL	System Data 1	Index 577	Assign 00H.
		Indexes 578	Assign when LAN output is used. (Bit 4** of each Index)

**\*\* Note:** When using LAN Interface for SMDR, a TCP/IP LAN Address, Subnet Mask Address, and Gateway Address must be assigned to the Active CPU. Use either ASYDL, Sys-1, Indexes 515 through 526 to assign these addresses or the ADTM command.

## S-10 Station Message Detail Recording (SMDR)

[Node B]

ASYD	System Data 1	Index 180	Assign the PC of Node B.
		Index 182	Assign the PC of Node C.
		Indexes 288 - 295	Assign all 00H.
ASYDL	System Data 1	Index 577	Assign 00H.
		Indexes 578 - 581	Assign all 00H.

[Node C]

ASYD	System Data 1	Index 180	Assign the PC of Node C.
		Indexes 288 - 295	Assign when RS-232C output is used.
ASYDL	System Data 1	Index 578	Assign when LAN output is used. (Bit 4** of each Index)

**\*\* Note:** When using LAN Interface for SMDR, a TCP/IP LAN Address, Subnet Mask Address, and Gateway Address must be assigned to the Active CPU. Use either ASYDL, Sys-1, Indexes 515 through 526 to assign these addresses or the ADTM command.

### Example 6

- Node A collects the billing information of Node B and Node C via FCCS, using the polling method.
- Node A sends the billing information of Node A, Node B and Node C to Node D.

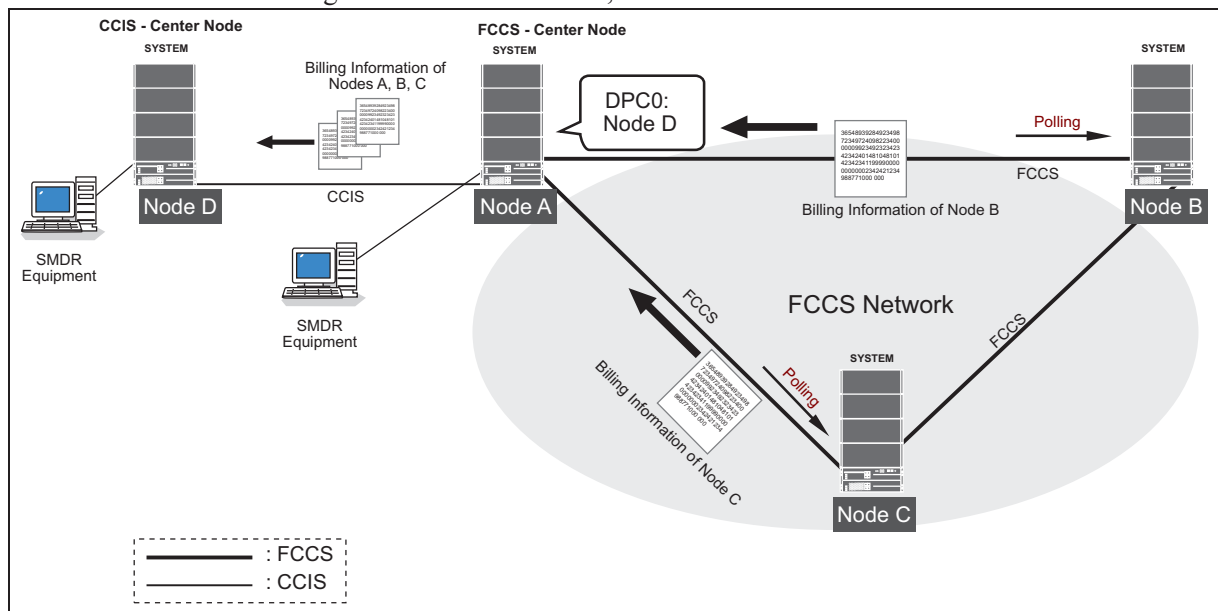

[Common Data]

ASYD	System Data 1	Indexes 32, 34
	System Data 2	Index 3

[Node A]

ASYD	System Data 1	Index 180	Assign the PC of Node A.
		Index 182	Assign the PC of Node D.
		Indexes 288	Assign when RS-232C output is used.
ASYDL	System Data 1	Index 576	Assign Bit 0 = 1 for Centralized FCCS SMDR In Service.
		Index 576	Assign Bit 2 = 1 (When using LAN interface for SMDR)
		Index 577	Assign 00H.
		Indexes 578	Assign when LAN output is used. (Bit 4** of each Index)
		Indexes 608	Assign Node B and Node C.

**\*\* Note:** When using LAN Interface for SMDR, a TCP/IP LAN Address, Subnet Mask Address, and Gateway

## S-10 Station Message Detail Recording (SMDR)

Address must be assigned to the Active CPU. Use either ASYDL, Sys-1, Indexes 515 through 526 to assign these addresses or the ADTM command.

[Node B and Node C]

ASYD	System Data 1	Indexes 288 - 295	Assign all 00H.
ASYDL	System Data 1	Index 576	Assign 01H.
		Index 577	Assign the FPC of Node A.
		Indexes 578 - 581	Assign all 00H.

[Node D]

ASYD	System Data 1	Index 180	Assign the PC of Node D.
		Indexes 288	Assign when RS-232C output is used.

### Example 7

- Node A collects the billing information of Node B and Node C via FCCS, using the polling method (Billing information of Node B cannot be collected).
- Node B sends the billing information to Node D via CCIS, ignoring polling from Node A.
- Node B deletes the Point Code (CCIS) for Node D when Node B wants to send billing information for polling from Node A.

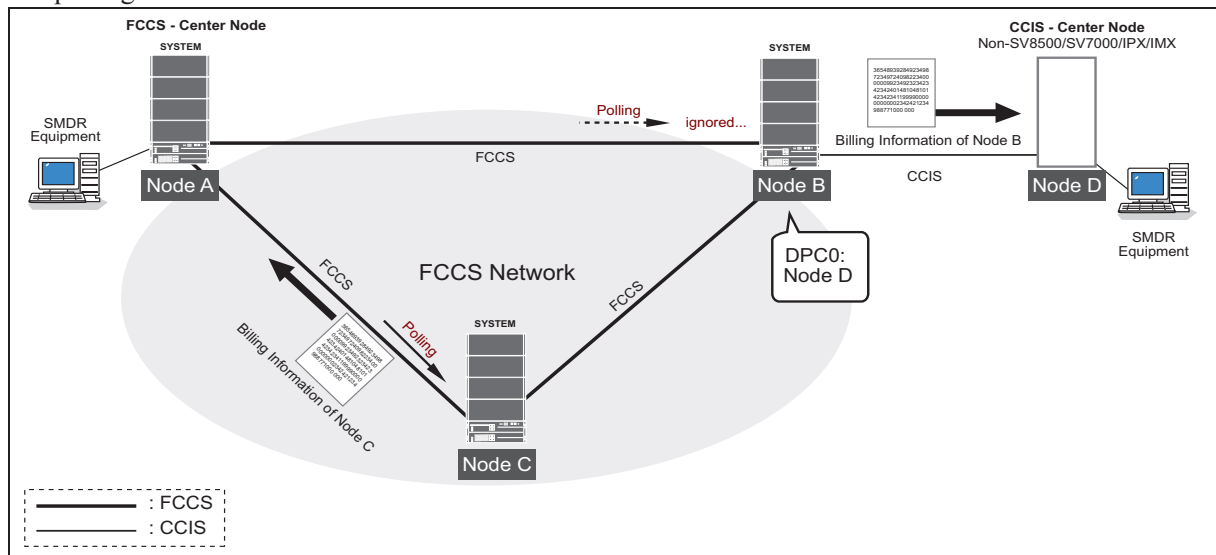

[Common Data]

ASYD	System Data 1	Indexes 32, 34
	System Data 2	Index 3

[Node A]

ASYD	System Data 1	Indexes 288	Assign when RS-232C output is used
ASYDL	System Data 1	Index 576	Assign Bit 0 = 1 for Centralized FCCS SMDR In Service.
		Index 576	Assign Bit 2 = 1 (when using LAN interface for SMDR)
		Index 577	Assign 00H.
		Indexes 578	Assign when LAN output is used. (Bit 4** of each Index)
		Indexes 608	Assign Node C.

**\*\* Note:** When using LAN Interface for SMDR, a TCP/IP LAN Address, Subnet Mask Address, and Gateway Address must be assigned to the Active CPU. Use either ASYDL, Sys-1, Indexes 515 through 526 to assign these addresses or the ADTM command.

[Node B]

ASYD	System Data 1	Index 180	Assign the PC of Node B
------	---------------	-----------	-------------------------

## S-10 Station Message Detail Recording (SMDR)

		Index 182	Assign the PC of Node D
		Indexes 288 - 295	Assign all 00H.
ASYDL	System Data 1	Index 576	Assign 00H.
		Index 577	Assign 00H.
		Indexes 578 - 581	Assign all 00H.
[Node C]			
ASYD	System Data 1	Indexes 288 - 295	Assign all 00H.
ASYDL	System Data 1	Index 576	Assign 01H
		Index 577	Assign the FPC of Node A.
		Indexes 578 - 581	Assign all 00H.
[Node D]			
ASYD	System Data 1	Index 180	Assign the PC of Node D.
		Indexes 288	Assign when RS-232C output is used.

### Example 8

- Node A collects the billing information of Node B, Node C and Node D, which are stored in Node B by polling method.
- Node D sends the billing information to Node B.

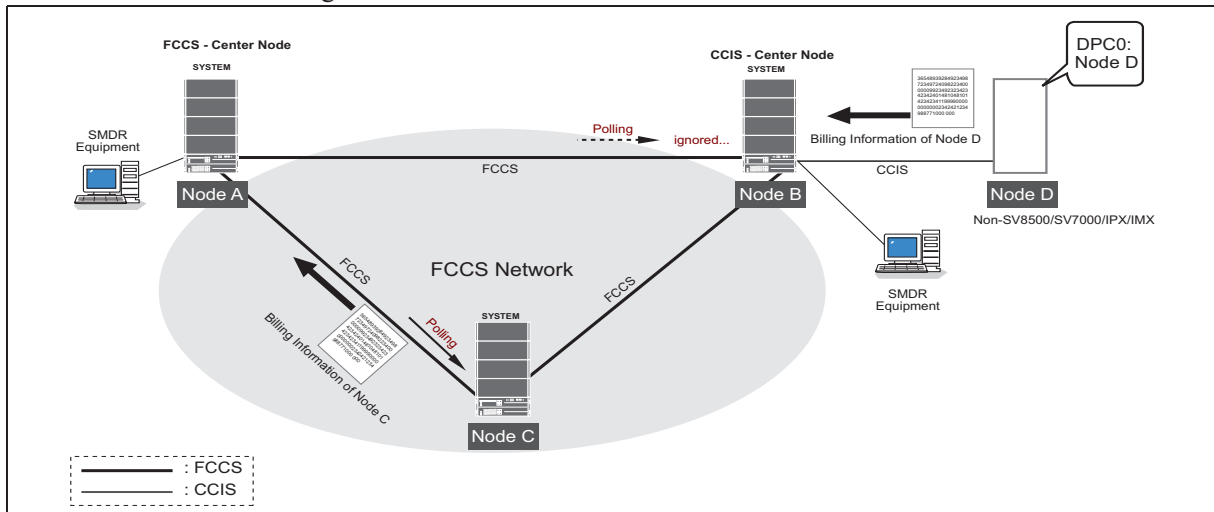

### [Common Data]

ASYD	System Data 1	Indexes 32, 34
	System Data 2	Index 3

### [Node A]

ASYD	System Data 1	Indexes 288	Assign when RS-232C output is used.
ASYDL	System Data 1	Index 576	Assign Bit 0 = 1 for Centralized FCCS SMDR In Service.
		Index 576	Assign Bit 2 = 1 (when using LAN interface for SMDR)
		Index 577	Assign 00H.
		Indexes 578	Assign when LAN output is used. (Bit 4** of each Index)
		Indexes 608	Assign Node B and Node C.

**\*\* Note:** When using LAN Interface for SMDR, a TCP/IP LAN Address, Subnet Mask Address, and Gateway Address must be assigned to the Active CPU. Use either ASYDL, Sys-1, Indexes 515 through 526 to assign these addresses or the ADTM command.

### [Node B]

## S-10 Station Message Detail Recording (SMDR)

ASYD	System Data 1	Index 180	Assign the PC of Node B
		Indexes 288	Assign when RS-232C output is used.
ASYDL	System Data 1	Index 576	Assign Bit 0 = 1 for Centralized FCCS SMDR In Service.
		Index 576	Assign Bit 2 = 1, when using LAN interface for SMDR.
		Index 577	Assign the FPC of Node A.
		Indexes 578 - 581	Assign when LAN output is used. (Bit 4** of each Index).

**\*\* Note:** When using LAN Interface for SMDR, a TCP/IP LAN Address, Subnet Mask Address, and Gateway Address must be assigned to the Active CPU. Use either ASYDL, Sys-1, Indexes 515 through 526 to assign these addresses or the ADTM command.

[Node C]

ASYD	System Data 1	Indexes 288 - 295	Assign all 00H.
ASYDL	System Data 1	Index 576	Assign 01H
		Index 577	Assign the FPC of Node A.
		Indexes 578 - 581	Assign all 00H.

[Node D]

ASYD	System Data 1	Index 180	Assign the PC of Node D.
		Index 182	Assign the PC of Node B.
		Indexes 288 - 295	Assign all 00H.

**Example 9**

- Node A collects the billing information of Node B and the self node.
- Node C and Node D also require SMDR data assignment.

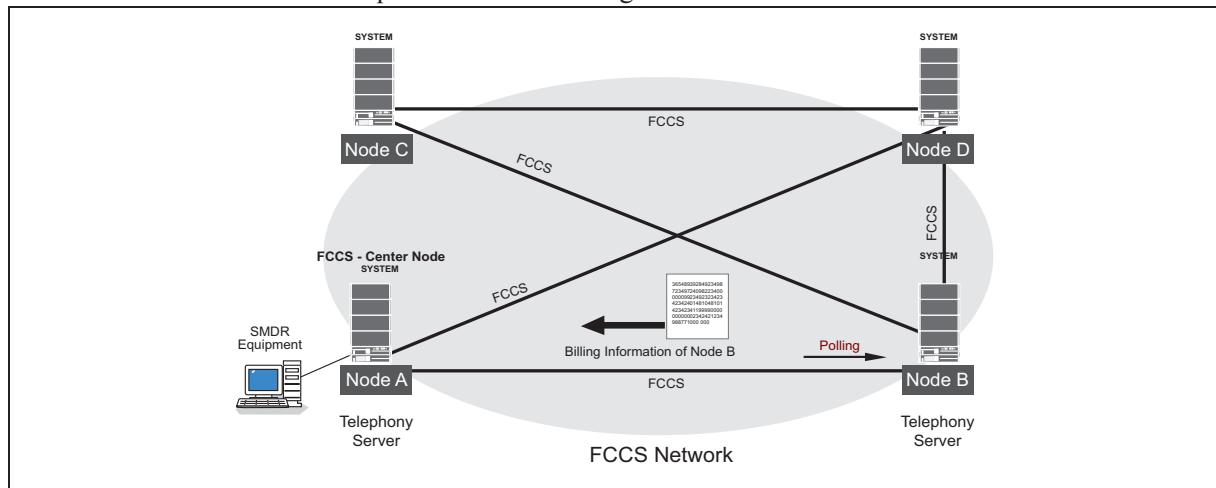

[Common Data]

ASYD	System Data 1	Indexes 32, 34	
	System Data 2	Index 3	
ASYDN		Index 583	Assign 00H.

[Node A]

ASYD	System Data 1	Indexes 288	Assign when RS-232C output is used.
ASYDL	System Data 1	Index 576	Assign Bit 0 = 1 for Centralized FCCS SMDR In Service.
		Index 576	Assign Bit 2 = 1 (when using LAN interface for SMDR)
		Index 577	Assign 00H.
		Indexes 578	Assign when LAN output is used. (Bit 4** of each Index)
		Indexes 608	Assign Node B.

**\*\* Note:** When using LAN Interface for SMDR, a TCP/IP LAN Address, Subnet Mask Address, and Gateway

## S-10 Station Message Detail Recording (SMDR)

---

Address must be assigned to the Active CPU. Use either ASYDL, Sys-1, Indexes 515 through 526 to assign these addresses or the ADTM command.

### [Node B]

ASYD	System Data 1	Indexes 288 - 295	Assign all 00H.
ASYDL	System Data 1	Index 576	Assign 01H
		Index 577	Assign the FPC of Node A.
		Indexes 578 - 581	Assign all 00H.

### [Node C and Node D]

ASYD	System Data 1	Indexes 288 - 295	Assign all 00H.
ASYDL	System Data 1	Index 576	Assign 00H
		Index 577	Assign 00H.
		Indexes 578 - 581	Assign all 00H.

- **SOCKET Interface (LAN Interface) Conditions:**

1. When you use the SMDR system with a LAN interface, be aware of the following:
  - When connecting to the SMDR system, simultaneous use of LAN and RS-232C connection is not available in a single node.
  - When you change the interface for the SMRD system (from LAN to RS-232C and vice versa), all the data collected in the Telephony Server is erased. Therefore, before performing such operation, output all the collected data to the SMDR system.
  - A detailed report cannot be output.
2. SMDR data can be output via LAN cable.
3. A maximum of four SMDR apparatuses per node are available.
4. When providing this feature with LAN interface, IMX text format must be designated by the ASYDL command (System Data 1, Index 578-581, Bit 0).
5. The LAN and RS232C interfaces cannot be used simultaneously for connecting SMDR equipment in the same node.

- **Relocation Condition for SMDR:**

When relocating SMDR equipment to another node, reassign the billing information-related data. The relocation conditions are shown below.

1. Make sure there is no billing information in the each node from the Center Node before changing the SMDR location. (make sure billing information is output to the SMDR by sending test signal.)
2. Exact billing information may not be output to SMDR while changing the SMDR location.
3. When removing the SMDR equipment from the Center Node, first delete all of the billing information-related data, and also when connecting the SMDR to new-Center Node, the user must, first of all, assign appropriate billing information-related data.
4. Assign the Fusion Point Code (FPC) of the new-Center Node to all nodes including the previous Center Node by ASYDL (System Data 1 Index 577).

- **Trunk Arrival Time and Abandoned Call Information (for Incoming Trunk Call):**

The following new information on Incoming Trunk Call can be output to SMDR:

**Note:** *This feature is available in EMEA only.*

- Trunk Arrival Time (when an incoming trunk call is terminated to the terminal)



## S-10 Station Message Detail Recording (SMDR)

---

- Abandoned Call as billing information for incoming trunk call

**Note:** *Answered Call:*

*Calling party releases the call after sending answer signal to the incoming trunk.*

*Call transferred to Announcement trunk by [C-25] Call Forwarding - Intercept/Announcement/[C-69]*

*Call Forwarding - All Calls - Announcement/[O-21] Outgoing Trunk Busy Announcements/[S-106]*

*Slumber Time - Do Not Disturb (routed to Announcement Trunk) is counted as answered call.*

*Call disconnected by [A-28] Automatic Announcement - Disconnected PS Out of Zone is counted as answered call (until the PS is in out of zone state).*

*Abandoned Call:*

*Calling party releases the call before sending answer signal to the incoming trunk.*

1. By using Trunk Arrival Time information, SMDR can calculate the ringing time (the time elapsed between Trunk Arrival and Call Start). The calculation method is as follows:

- In the case of Answered Call:

$$\text{Ringing Time} = \text{Call Start Time} - \text{Trunk Arrival Time}$$

- In the case of Abandoned Call:

$$\text{Ringing Time} = \text{Call End Time (Ringing stop time)} - \text{Trunk Arrival Time}$$

Example:

- In the case of Answered Call:

Trunk Arrival Time	2005/04/01	15:30:02:000
Call Start Time	2005/04/01	15:30:24:500
Call End Time	2005/04/01	15:35:15:500

- In the case of Abandoned Call:

Trunk Arrival Time	2005/04/01	15:30:02:200
Call Start Time	Blank	
Call End Time	2005/04/01	15:30:57:500

2. To output Trunk Arrival Time and Abandoned Call information, KL message must be activated. They cannot be output with KK message (Trunk Outgoing billing) or KM message (Station-to-Station billing).
3. Trunk Arrival Time and Abandoned Call information can be provided when an incoming call from C.O. line is terminated to Station, Attendant Control or trunk.
4. Trunk Arrival Time and Abandoned Call information can be provided on a route basis.
5. Called Party Number information on Abandoned Call is as follows:
  - a.) When called Station or Attendant Console can be identified, its number is output.
  - b.) When called Station cannot be identified ([T-23D] Trunk Line Appearance -D, etc.), the following information is output:

ORIG: 0 (Station)

Tenant: Tenant Information of Incoming Trunk

Called Party Number: Blank (Called Party cannot be identified)

## S-10 Station Message Detail Recording (SMDR)

---

- c.) When called Attendant Console cannot be identified ([D-114] Delay Announcement - Attendant, [A-55] Automatic Change of Night Service, Ring-down termination or [S-106] Slumber Time - Do Not Disturb (routed to Attendant Console), etc.), the following information is output:

ORIG: 1 (Attendant Console)  
Tenant: Tenant Information of Incoming Trunk  
Called Party Number: Blank (Called Party cannot be identified)

- d.) When [A-82] Automated Attendant/[R-2] Remote Access to System call is abandoned while the Calling Party Number is dialed, the following information is output:

ORIG: 0 (Station)  
Tenant: Tenant Information of Incoming Trunk  
Called Party Number: Blank (Called Party cannot be identified)

- e.) When an incoming call is forwarded by the following features, the forwarding destination number is output as the Called Party Number:

[C-5] Call Forwarding - All Calls  
[C-2] Call Forwarding - Busy Line  
[L-53] Logged Out IP Station - Call Destination  
[C-103] Calling Party Recognition Service (Call Forwarding-All Calls/Busy Line)

- f.) When an incoming call is forwarded by the following features, the number that has been set as forwarding destination is output as Called Party Number. Even when the call is forwarded to second hop forwarding destination, the first forwarding destination is output.

[C-3] Call Forwarding - Don't Answer  
[C-103] Calling Party Recognition Service (Don't Answer)  
[C-74] Call Forwarding - Don't Answer - Outside  
[C-47] Call Forwarding - Don't Answer - CCIS  
[C-155] Call Forwarding PS Incoming Call Incomplete

- g.) When an incoming call is forwarded by the following features, the trunk number that is used for the forwarding feature is output as Called Party Number.

[C-28] Call Forwarding - All Calls - Outside  
[C-45] Call Forwarding - All Calls - CCIS  
[C-60] Call Forwarding - Busy Line - Outside  
[C-46] Call Forwarding - Busy Line - CCIS  
[T-1] Tandem Switching of TIE Trunks - 2/4-Wire

- h.) When an incoming call is forwarded by the following features, Blank is output as Called Party Number.

Unused Number/Dead Level Number-Announcement

6. In the following cases, billing information is not output to SMDR (Forwarding features is not set):

- Target terminal is busy
- Target terminal is unassigned terminal

## S-10 Station Message Detail Recording (SMDR)

---

- Connection between target terminal and incoming trunk is restricted
- Target terminal sets Do Not Disturb feature
- Target terminal is locked out
- Register is busy

**Note:** When ASYD, SYS 1, Index 7, Bit 5 = 1:

If unassigned number or restricted number is dialed, the following information is output:

- ORIG: 0 (Station)
  - Tenant: Tenant Information of Incoming Trunk
  - Called Party Number: Blank (Called Party cannot be identified)
7. For features activated while in busy state such as Transfer-All Calls and Blind Transfer, etc., billing information on abandoned call is not provided.
  8. The relationship between the time until occurrence of billing buffer overflow and the number of incoming calls (Answered Call and Abandoned Call) per one hour is as follows:

5,000 calls/hour → 9.40 hours  
 10,000 calls/hour → 4.70 hours  
 15,000 calls/hour → 3.13 hours  
 20,000 calls/hour → 2.35 hours  
 20,000 calls/hour → 1.88 hours  
 30,000 calls/hour → 1.56 hours  
 \*billing buffer: 47,000 calls

9. The following shows the output availability of billing information on Abandoned Call:

• ISDN Features

Feature Code	Feature Name	Abandoned Call	
		Output of Billing Information	Called Party Number
D-123	Direct Inward Dialing (DID) Addressing	×	Called Party
C-104	Calling Party Recognition Service (Direct-In Termination [DIT])	×	Called Party
C-103	Calling Party Recognition Service (CF-All Calls)	×	Forwarding Destination Terminal
C-103	Calling Party Recognition Service (CF-Busy Line)	×	Forwarding Destination Terminal
C-103	Calling Party Recognition Service (CF-Don't Answer)	×	Terminal that has been set as forwarding destination

**S-10 Station Message Detail Recording (SMDR)**

• PCS/PHS Features

Feature Code	Feature Name	Abandoned Call	
		Output of Billing Information	Called Party Number
P-71	PS Line Appearance on Dterm	×	PS
A-129	Automatic Announcement - Called PS Out of Zone	×	PS
C-155	Call Forwarding PS Incoming Call Incomplete	×	PS
A-128	Automatic Announcement - Disconnected PS Out of Zone	Answered Call	PS

• Incoming Call Features

Feature Code	Feature Name	Abandoned Call	
		Output of Billing Information	Called Party Number
D-8	Direct Inward Dialing (DID)	×	Called Party
R-2/A-82	Remote Access to System/Automated Attendant	×	Called Party
D-7	Direct-In Termination (DIT)	×	Called Party
T-23D	Trunk Line Appearance-D	×	Blank
S-106	Slumber Time - Do Not Disturb (routed to Attendant Console)	×	Blank
	Slumber Time - Do Not Disturb (routed to Announcement Trunk)	Answered Call	Announcement Trunk

• Other Features

Feature Code	Feature Name	Abandoned Call	
		Output of Billing Information	Called Party Number
U-1	Uniform Call Distribution (UCD)	×	Called Party
D-31	Delay Announcement - UCD	N	-
O-13	Overflow - UCD *	N	-
C-25	Call Forwarding - Intercept / Announcement	Answered Call	Announcement Trunk

*\* When a call is abandoned while waiting in the first UCD queue:*

**S-10 Station Message Detail Recording (SMDR)**

• CCIS Features

Feature Code	Feature Name	Abandoned Call	
		Output of Billing Information	Called Party Number
C-45	Call Forwarding - All Calls - CCIS	×	Trunk
C-46	Call Forwarding - Busy Line - CCIS	×	Trunk
C-47	Call Forwarding - Don't Answer - CCIS	×	Terminal that has been set as forwarding destination
S-52	Serial Call - CCIS	N	-

• Attendant Console Features

Feature Code	Feature Name	Abandoned Call	
		Output of Billing Information	Called Party Number
S-15	Serial Call	N	-
D-114	Delay Announcement - Attendant	×	Blank
A-55	Automatic Change of Night Service	×	Blank

• Station Features

Feature Code	Feature Name	Abandoned Call	
		Output of Billing Information	Called Party Number
C-12	Call Waiting - Terminating	N	-
-	Unused Number/Dead Level Number-Announcement	×	Blank
C-5	Call Forwarding - All Calls	×	Forwarding Destination Terminal
C-2	Call Forwarding - Busy Line	×	Forwarding Destination Terminal
C-3	Call Forwarding - Don't Answer	×	Terminal that has been set as forwarding destination
C-28	Call Forwarding - All Calls - Outside	×	Trunk
C-60	Call Forwarding - Busy Line - Outside	×	Trunk

**S-10 Station Message Detail Recording (SMDR)**

Feature Code	Feature Name	Abandoned Call	
		Output of Billing Information	Called Party Number
C-74	Call Forwarding - Don't Answer - Outside	×	Terminal that has been set as forwarding destination
S-7 S-8 S-9 S-138 S-139	Station Hunting - Circular Station Hunting - Secretarial Station Hunting - Terminal Station Hunting - Priority Station Hunting - Priority with Switchback	×	Called Terminal
C-69	Call Forwarding - All Calls - Announcement	Answered Call	Announcement Trunk

• Network Features

Feature Code	Feature Name	Abandoned Call	
		Output of Billing Information	Called Party Number
T-1	Tandem Switching of TIE Trunks - 2/4-Wire	×	Trunk
O-21	Outgoing Trunk Busy Announcements	Answered Call	Announcement Trunk

• IP Features

Feature Code	Feature Name	Abandoned Call	
		Output of Billing Information	Called Party Number
L-53	Logged Out IP Station - Call Destination	×	Destination Terminal

10. As in the following, if Split Billing is applied, the same value is output as Trunk Arrival Time for the conversations between “Trunk C and Terminal A” and “Trunk C and Terminal B”.
  - 1.) An Incoming Trunk C Call is terminated to Terminal A.
  - 2.) Trunk C and Terminal A are engaged in a two-way conversation.
  - 3.) Trunk C is placed on hold, and the call is transferred to Terminal B from Terminal A.
  - 4.) Terminal A goes on-hook. Trunk and Terminal B are engaged in a two-way conversation.  
(Billing Information for the conversation between Trunk C and Terminal A is output.)
  - 5.) Conversation between Trunk C and Terminal B ends.  
(Billing Information for the conversation between Trunk C and Terminal B is output.)
11. When using Centralized Billing - CCIS feature, Trunk Arrival Time information of Local node is not included in the billing information to be sent to Center node.
12. When a call is established or released while in the following states, Trunk Arrival Time is not output:

## S-10 Station Message Detail Recording (SMDR)

---

- Delay Announcement - UCD
  - Overflow - UCD
  - Call Waiting
13. When using Centralized Billing - CCIS feature, Abandoned Call information of Local node is not sent to Center node.

---

## S-10 Station Message Detail Recording (SMDR)

---

### Interactions

1. If LCR(S) is provided, the LCR(S) Access Code is listed in ARNP. If an outgoing route is not used in LCR(S), then list the OGCA Access Code in ARNP.
2. To test SMDR output, it is recommended that a serial printer, breakout box, or a TCP/IP based tool be used to determine if the system is sending data.
3. CALL TRANSFER-ALL CALLS [C-11]: Either the first Station, last Station, or split billing is allowed with SMDR. Split billing provides a separate call record for both before and after a Call Transfer.
4. ATTENDANT CAMP-ON WITH TONE INDICATION [A-1]: The Called Station Number is recorded for Incoming Central Office Calls via the Attendant Console (RRI 2 of ARSC). To record the time a Destination Station is on a call, split billing or last Station billing is required. With split billing, the time the Attendant Console is on the call is separated from the time the Destination Station is on the call. For last Station billing, the Destination Station is charged with the entire time of Connection.
5. LEAST-COST ROUTING-3/6-DIGIT [L-5]: SMDR will record the digits sent rather than the digits dialed.
6. The Destination Station is recorded on SMDR for the following features:

CALL FORWARDING	[C-2, 3, 5]
CALL PICKUP	[C-7, 30]
7. CALL FORWARDING-INTERCEPT [C-25]: An Incoming Trunk Call responds to Call Forwarding-Intercept to the Attendant Console. SMDR records the call as if it is a direct call to the Attendant Console.
8. NIGHT CONNECTION-FIXED/FLEXIBLE [N-1, 2]: Calls terminated to these Stations are recorded on SMDR.
9. OUTGOING TRUNK QUEUING [O-2]: SMDR records the Outgoing Call when the system recalls the user and the digits are sent, not when the Trunk is queued.
10. REMOTE ACCESS TO SYSTEM [R-2]: The Incoming Route and Trunk Number is recorded as the Calling Party. If FORCED ACCOUNT CODE [F-7] is used, it will be recorded on SMDR. REMOTE ACCESS TO SYSTEM via a DID will not record FORCED ACCOUNT CODE on SMDR.
11. TRUNK-TO-TRUNK CONNECTION [T-10] and TIE LINE ACCESS [T-3]: SMDR records an Incoming TIE Line that uses TRUNK-TO-TRUNK CONNECTION to make an Outgoing Call. The TIE Line Route and Trunk Number is recorded as the Calling Party. The outgoing route is programmed for SMDR in ARTD, not the Incoming TIE Line Route.
12. CALL WAITING-TERMINATING [C-12]: SMDR will begin recording the call when the call is answered, not when a Call Waiting Tone is heard.



## S-10 Station Message Detail Recording (SMDR)

### Programming

STEP 1: **ASYD** - System Data 1, Index 20, Bit 7. Charging to a call transferred by CALL FORWARDING-OUTSIDE Service 0/1: Charging is made to the caller of the Transferred Call / charging is made to the Station that has set CALL FORWARDING-OUTSIDE service.

System Data 1, Index 32

Bit 1 = 1 (records Tenant information)

Bit 2 = 1 (records route information)

Bit 5 = 1 (records Route Access Code)

Bit 6: 0/1 (records Number Sent/Number Dialed as SMDR Called Party Number Registration Type)

Bit 7 = 1 (enables SNDR service)

System Data 1, Index 33. Assign this Index for Split Billing. When Split Billing is used, assign 00H. When Total Billing is used, Bits 3 and 4 represent the following:

ASYD System Data 1, Index 33		
Bit 4	Bit 3	Telephone Subject to Total Billing
0	0	Telephone called first (regardless of calling party kind)
0	1	Telephone called last (regardless of calling party kind)
1 Note	0	First telephone after the call has been handled by ATT
1 Note	1	Telephone called last (regardless of calling party kind)

**Note:** When Bit 4 is set, the intermediate ATT information will be output to SMDR.

Bit 5 must be assigned as data "1" to provide total billing for Incoming Calls.

Bit 6 must be assigned as data "1" to provide total billing for Outgoing Calls.

**Note:** When using Split Billing, if an outgoing call is made via ISDN, billing information will not be displayed.

**Note:** When using Split Billing, the following condition must be considered.

When a Station transfers the trunk call to Attendant Console via BLIND TRANSFER [B-18], Total Billing for Incoming Call to the answered Station is output to SMDR.

System Data 1, Index 34. Assign data 01H or 21H. Bit 0 enables RS-232C transmission.

Bit 0: SMDR RS-232 C Output. 0/1 = Out of Service/In Service

Bit 5: The converted number is sent to the SMDR. 0/1 = Original Number is sent/Converted Number is sent

System Data 1, Index 58, Bit 7. Is the Specific Attendant Number, assigned by ASAT/ASATN command output to SMDR terminal? 0/1: No/Yes.

**Note:** When the Originating Point Code (OPC) is assigned by System Data 1 Index 180 and 181 and Attendant Console originates the call, the Specific Attendant Number is output even if System Data 1 Index 58 Bit 7 = 0.

System Data 1, Index 95. Maximum Buffer Capacity for Storing SMDR (RS-232C)

Bit 0-3: 0-9 (10-minute basis)

Bit 4-7: 0-9 (100-minute basis)

**Note:** Used for SMDR by RS-232C only. When 00H is assigned, 180 minutes (= 3hours) will be applied. 10-990 minutes (=16.5hours) can be assigned for billing by 10-minutes basis.

System Data 1, Index 157. Outgoing Trunk, Soft Hold Timer. The point in time when the system will recognize an Outgoing Call as answered. Default is 18 seconds. Because of interaction with momentary pressing of the hook-switch, this data may be reassigned as 31H for two seconds. Take the SMDR aspect into consideration when reassigning this data.

## S-10 Station Message Detail Recording (SMDR)

---

System Data 1, Index 174, Bit 5. SMDR output method in CCIS/ISDN tandem node. Specify the information n type of calling party in the outgoing call via CCIS (Calling Party Number in ISDN). (0/1 = Station Number/Route Number and Trunk Number of Incoming Trunk)

**Note:** *In CCIS Network, the number is limited to six digits including the node number of RT=0 in the ARNP command.*

**Note:** *Set Bit 5 when using IS-11572/Dp Channel so that billing may be processed by using Route Number of Incoming Trunk. If 0 is assigned in this instance, billing will not applied correctly on the ground that the Calling Party Number cannot be referred to.*

**Note:** *If 0 is assigned for this data, when [T-1] Tandem Switching of TIE Trunks - 2/4-Wire is used in CCIS network, the billing information output at tandem node will be changed depending on the System Data - ASYD, Sys 1, Index 241, Bit 6. (Process to be executed when the length of Caller ID exceeds the limits)*

### **[Example]**

*When Calling Party Number is 123456789 and limited to 8 digits:*

*In the case of Index 241, bit 6 =0, the calling party number will be set as 1234567\*. (8 digits will be displayed including \* that indicates that there is an information not being displayed. The six digits from the top digit will be output as the billing information. (123456))*

*In the case of Index 241, bit 6 =1, the calling party number will be set as \*3456789. (8 digits will be displayed including \* that indicates that there is an information not being displayed. The six digits from the top digit will be output as the billing information. (\*34567))*

System Data 1, Index 249. SMDR output buffer usage rate to *output* Alarm Message (default = 80%)

Bit 0-3: value in the 1's place of buffer usage rate (0 - 9)

Bit 4-7: value in the 10's place of buffer usage rate (0 - 9)

Usage Rate to output Alarm Message: 

b7	b6	b5	b4	b3	b2	b1	b0
value in 10's place				value in 1's place			

System Data 1, Index 250. SMDR output buffer usage rate to *clear* Alarm Message (default = 50%)

Bit 0-3: value in the 1's place of buffer usage rate (0 - 9)

Bit 4-7: value in the 10's place of buffer usage rate (0 - 9)

Usage Rate to clear Alarm Message: 

b7	b6	b5	b4	b3	b2	b1	b0
value in 10's place				value in 1's place			

System Data 1, Indexes 288-295 (Required for SMDR by RS-232C only)

Designation of the attributes of the SMDR.

SMDR output port will be designated. For this designation, the attributes of the terminal that outputs the detail call information should have been designated by Indexes 117-123. (Assigned by the AIOC command.)

Also for detecting a fault of the SMDR, set the SMDR fault detect timer.

Index 288 = Charging information port of SMDR A.

Bit 4: IOC Equipment Number (0/1 = No.0/No.1)

Bit 5: Expanded SMDR Output (0/1 = Out/In Service)

## S-10 Station Message Detail Recording (SMDR)

---

Index 289 = SMDR fault detect timer of SMDR A. **Note 1 Note 2**

Bit 0-3: Fault detection timer of SMDR A Value for the first digit (minutes)

Bit 4-7: Fault detection timer of SMDR A Value for the second digit (minutes)

Index 290 = Charging information port of SMDR B.

Bit 4: IOC Equipment Number (0/1 = No.0/No.1)

Bit 5: Expanded SMDR Output (0/1 = Out/In Service)

Index 291 = SMDR fault detect timer of SMDR B. **Note 1 Note 2**

Bit 0-3: Fault detection timer of SMDR B Value for the first digit (minutes)

Bit 4-7: Fault detection timer of SMDR B Value for the second digit (minutes)

Index 292 = Charging information port of SMDR C.

Bit 4: IOC Equipment Number (0/1 = No.0/No.1)

Bit 5: Expanded SMDR Output (0/1 = Out/In Service)

Index 293 = SMDR fault detect timer of SMDR C. **Note 1 Note 2**

Bit 0-3: Fault detection timer of SMDR C Value for the first digit (minutes)

Bit 4-7: Fault detection timer of SMDR C Value for the second digit (minutes)

Index 294 = Charging information port of SMDR D.

Bit 4: IOC Equipment Number (0/1 = No.0/No.1)

Bit 5: Expanded SMDR Output (0/1 = Out/In Service)

Index 295 = SMDR fault detect timer of SMDR D. **Note 1 Note 2**

Bit 0-3: Fault detection timer of SMDR D Value for the first digit (minutes)

Bit 4-7: Fault detection timer of SMDR D Value for the second digit (minutes)

**Note 1:** (0-9) HEX is used only. (A-F) HEX is not used. If (A-F) HEX is assigned for bit 0-3 and bit 4-7, SMDR fault cannot be detected.

**Note 2:** In the case of 00 HEX (default), system message will not be output for SMDR fault.

System Data 2, Index 3. Bit 0 enables SMDR registration per Tenant.

System Data 2, Index 3. Optional assignments for Station-to-Station Connection.

Bit 5: Code Type (0/1 = Authorization/Forced Account) assign as "1" for Authorization Code to be present in SMDR.

Bit 7: Station-to-Station SMDR in service (0/1 = No/Yes)

System Data 1, Index 18, Bit 4. To enable the output of Trunk Arrival Time and Abandoned Call information, Assign as "1".

STEP 2: **ASYDL** - System Data 1, Index 576

Bit 0: Centralized Billing-FCCS (Polling Method): 0/1 = Not/To be provided. Required both for Center Node and each Local Node.

Bit 1: SMDR for Station to Station Connections in a Self Node 0/1 = output/not output **Note 1**

Bit 2: SMDR Interface Type 0/1 = RS-232C interface is used/LAN interface is used.

System Data 1, Index 577.

Fusion Point Code (FPC) of Center Node.

Provided that "1" is flagging in Bit 0 of Index 576 (System Data 1), let every Local Node recognize its belonging Center Node for centralized billing-FCCS. Assign data on Center Node FPC at each Local Node. Given this data, the Local Nodes can acknowledge the SMDR polling only from the Center Node specified here (the polling from other parties will be ignored).

At the Center Node, assign 00H.

System Data 1, Index 578-581, Bit 0. Assign correct data (0/1) for regulation of output text format pattern for centralized billing-FCCS. Index 578 corresponds to SMDR A, 579 to SMDR B, 580 to SMDR C and 581 to SMDR D. **Note 2** The pattern to be adopted will be:

## S-10 Station Message Detail Recording (SMDR)

Bit 0 = 0: ICS text format.

Bit 0 = 1: IMX format.

System Data 1, Index 582, Bit 0-3. Assign the number of nodes to be polled at once.

0000 = 1	0001 = 1	0010 = 2	0011 = 3	0100 = 4	0101 = 5
0110 = 6	0111 = 7	1000 = 8	⏟		1111 = 8 <b>Note 3</b>

**Note 1:** This data is valid when the data is assigned at System Data 1, Index 512.

**Note 2:** The same billing information can be output to a maximum of four pieces of SMDR equipment.

**Note 3:** For the numbers more than 8, assign the data value as 8.

System Data 1, Index 583, Bit 0-2. The timing for FCCS billing data transmission from the node that accommodates the Outgoing Trunk or the node that accommodates the Called Station to the node that accommodates the Calling Party (Valid when System Data 1, Index 583, Bit 7 = 0 in ASYDN).

Bit 2 1 0

Bit 2 1 0

0 0 0 = eight seconds	1 0 0 = eight seconds
-----------------------	-----------------------

0 0 1 = two seconds	1 0 1 = 10 seconds
---------------------	--------------------

0 1 0 = four seconds	1 1 0 = 12 seconds
----------------------	--------------------

0 1 1 = six seconds	1 1 1 = 14 seconds
---------------------	--------------------

System Data 1, Index 608-639.

Fusion Point Code (FPC) of SMDR polling destination.

After the Center Node (multiple CN: possible on a network) is assigned for centralized billing-FCCS, let the Center Node recognize its polling destination (specified by the FPC), referring to the table below. In the table, each Bit represents Fusion Point Code ranging from 1 to 253. When “1” is set, the FPC is specified as the polling destination.

Index	b7	b6	b5	b4	b3	b2	b1	b0
<b>608</b>	7	6	5	4	3	2	1	-
<b>609</b>	15	14	13	2	11	10	9	8
<b>610</b>	23	22	21	20	19	18	17	16
<b>611</b>	31	30	29	28	27	26	25	24
<b>612</b>	39	38	37	36	35	34	33	32
<b>613</b>	47	46	45	44	43	42	41	40
<b>614</b>	55	54	53	52	51	50	49	48
<b>615</b>	63	62	61	60	59	58	57	56
<b>616</b>	71	70	69	68	67	66	65	64
<b>617</b>	79	78	77	76	75	74	73	72
<b>618</b>	87	86	85	84	83	82	81	80
<b>619</b>	95	94	93	92	91	90	89	88
<b>620</b>	103	102	101	100	99	98	97	96
<b>621</b>	111	110	109	108	107	106	105	104
<b>622</b>	119	118	117	116	115	114	113	112
<b>623</b>	127	126	125	124	123	122	121	120
<b>624</b>	135	134	133	132	131	130	129	128
<b>625</b>	143	142	141	140	139	138	137	136

### S-10 Station Message Detail Recording (SMDR)

Index	b7	b6	b5	b4	b3	b2	b1	b0
626	151	150	149	148	147	146	145	144
627	159	158	157	156	155	154	153	152
628	167	166	165	164	163	162	161	160
629	175	174	173	172	171	170	169	168
630	183	182	181	180	179	178	177	176
631	191	190	189	188	187	186	185	184
632	199	198	197	196	195	194	193	192
633	207	206	205	204	203	202	201	200
634	215	214	213	212	211	210	209	208
635	223	222	221	220	219	218	217	216
636	231	230	229	228	227	226	225	224
637	239	238	237	236	235	234	233	232
638	247	246	245	244	243	242	241	240
639	-	-	253	252	251	250	249	248

System Data 1, Index 641,

Bit 0: Type of the Station Number for the ICS text format.

0/1 = Physical Station Number/Telephone Number.

**Note:** *If the Telephone Number is within 6 digits, the Telephone Number will be output.*

Bit 3: Kind of the Route Number for the ICS text format.

0/1 = Physical Route Number/Logical Route Number.

STEP 3: SOCKET Interface (LAN Interface) Programming

System Data 1, Index 529, Bit 0-1: Assign the methods of parity check

00 = Odd Parity (Default)

01 = Odd Parity

10 = Even Parity

11 = No Parity check

Index 576, Bit 2: SMDR Interface Type 0/1 = RS-232C interface is used/LAN interface is used.

Index 578-581, Bit 4: Assign the usage of the SMDR.

Index 578, Bit 4: 0/1 = SMDR A is not used/used

Index 579, Bit 4: 0/1 = SMDR B is not used/used

Index 580, Bit 4: 0/1 = SMDR C is not used/used

Index 581, Bit 4: 0/1 = SMDR D is not used/used

Index 588, Bit 0: Output station number of transferring party to SMDR as originating party in Blind Transfer 0/1 = Out of service/In service

**Note:** *This data is valid when ASYD SYS1, Index 20, b7=1 and Index33=60 or 68 HEX. is assigned.*

STEP 4: **ASYDN** - This data should be set "0" for ASYDL, System Data 1, Index 583, Bit 0-2. Index 583, Bit 7.

The node for saving FCCS billing data:

0 = The Node accommodating the Calling Party

1 = The Node accommodating the Outgoing Trunk or the Called Station

## S-10 Station Message Detail Recording (SMDR)

STEP 5: **AIOC** - Assign the function and attribute data of the IOC ports.

This data is required when using RS-232C interface, not necessary when using LAN interface.

STEP 6: **ADTM** - Specify the Port Number used for SMDR within the range of 1024 to 65534. When "0" is set, the default value (60010) is automatically used.

STEP 7: **ARTD** - CDN 10: SMDR. Enable outgoing routes to be included for SMDR registration.

CDN 16: SMDR2. Assign Detail Billing Information data. For details, see Command Manual.

**Note:** To enable Billing for Incoming Call, assign 1 to CDN16 (SMDR2).

**Note:** When assigning Logical Route, use ARTDN command.

**Note:** To change the data for existing route (RT), initialize or reboot the trunk device such as circuit card, MG, or VS-32.

CDN 56: SMDR3. Detailed billing for outgoing in tandem connection.

0/1 = Required/Not required.

**Note:** Make this setting for the incoming route (ICRT) at the relaying node. For details, see <Case Where Detailed Billing for Outgoing in Tandem Connection is Not Required (CDN 56 = 1)>.

<Case Where Detailed Billing for Outgoing in Tandem Connection is Not Required (CDN 56 = 1)>

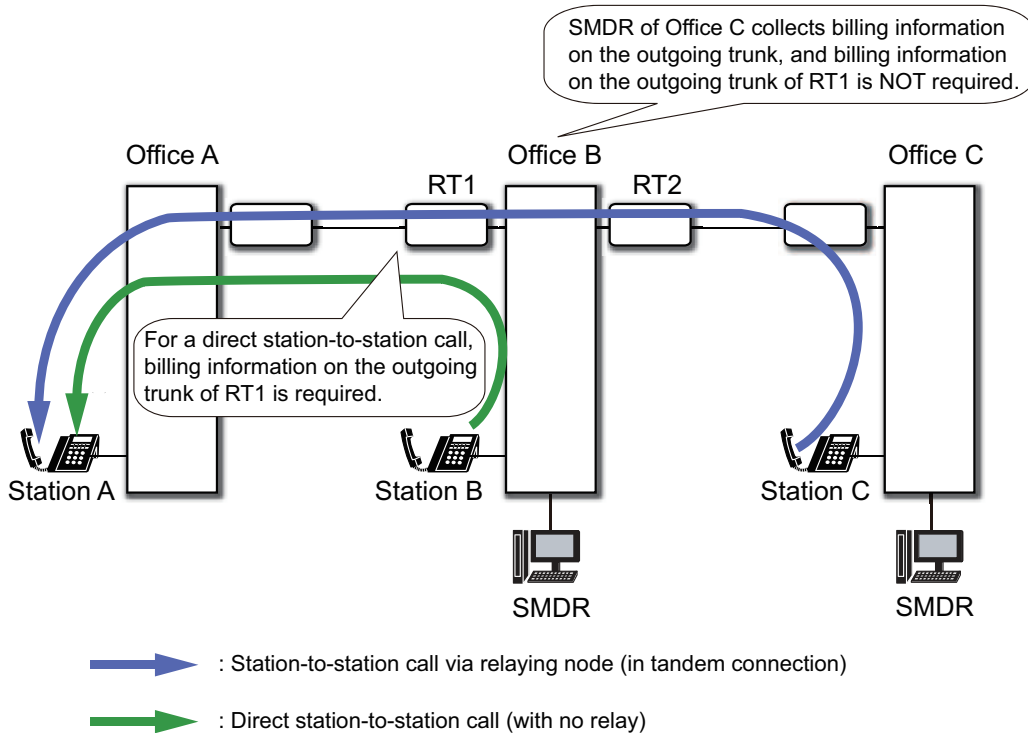

In the network shown above, Office B functions as a tandem switch. Office A has no SMDR.

When Station C places a call to Station A, the SMDR of Office C collects billing information on the outgoing trunk. Therefore, billing information on the outgoing trunk of RT1 is not required.

When Station B places a call to Station A, the billing information on the outgoing trunk of RT1 is required since Office A has no SMDR.

By assigning the Route Class data (ARTD, CDN56: SMDR3 = 1) to the incoming trunk of RT2, you can program the system so that the SMDR of Office B gathers billing information on RT1 only when the outgoing call is originated from a station in Office B.

## S-10 Station Message Detail Recording (SMDR)

CDN 69: SMDR4. Detailed billing for incoming in tandem connection.

0/1 = Required/Not required.

**Note:** Make this setting for the outgoing route (OGRT) at the relaying node. For details, see <Case Where Detailed Billing for Incoming in Tandem Connection is Not Required (CDN 69 = 1)>.

<Case Where Detailed Billing for Incoming in Tandem Connection is Not Required (CDN 69 = 1)>

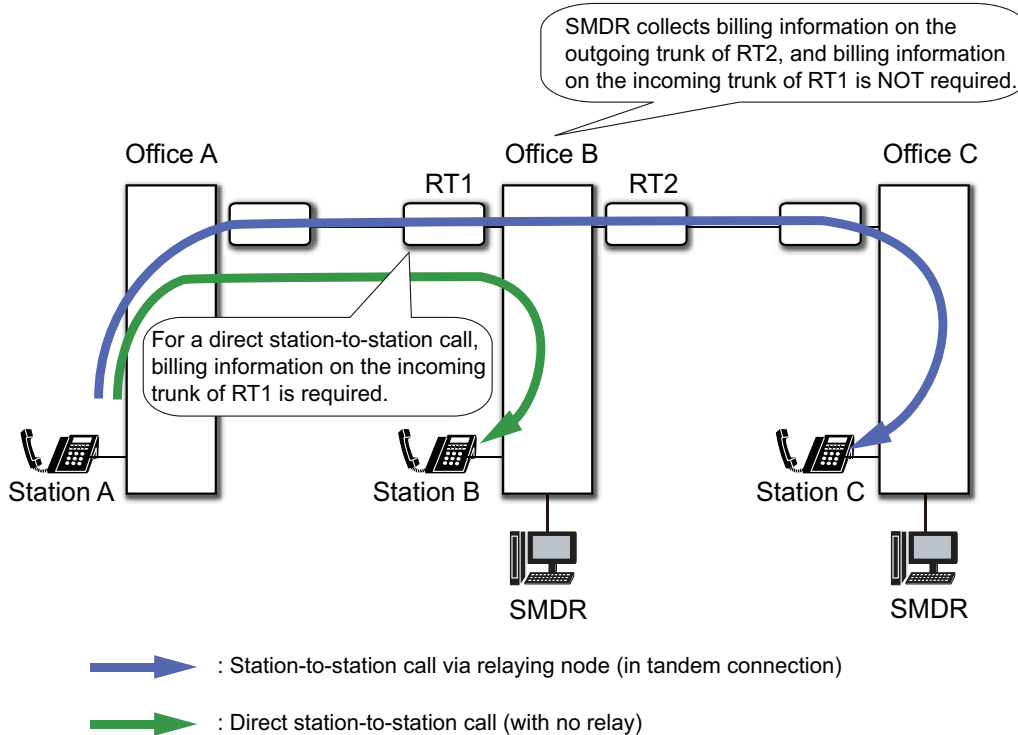

In the network shown above, Office B functions as a tandem switch. Office A has no SMDR.

When Station A places a call to Station C, the SMDR of Office B collects billing information on the outgoing trunk of RT2. Therefore, billing information on the incoming trunk of RT1 is not required.

When Station A places a call to Station B, the billing information on the incoming trunk of RT1 is required since Office A has no SMDR.

By assigning the Route Class data (ARTD, CDN69: SMDR4 = 1) to the outgoing trunk of RT2, you can program the system so that the SMDR of Office B gathers billing information on RT1 only when the incoming call terminates to a station in Office B.

### S-10 Station Message Detail Recording (SMDR)

STEP 8: **ARTI** - To enable the output of Trunk Arrival Time and Abandoned Call information, assign CDN 90 (SMDS5) = 1.

**Note:** When assigning Logical Route, use ARTIN command.

**Note:** To change the data for existing route (RT), initialize or reboot the trunk device such as circuit card, MG, or VS-32.

**Note:** Also, to enable this feature, it is necessary to enable SMDR billing for incoming call by the data setting of CDN 70 (CSMDS). The following table and figure show the office data setting pattern for Incoming Call Billing:

ARTD/ARTDN CDN 16 (SMDR2) Bit 0	ARTI/ARTIN CDN 90 (SMDS5) Bit 0	ARTI/ARTIN CDN70 (CSMDS) Bit 1 (*1)	ASFC SFI 14 (System Message Detail Recording (SMDR) - Trunk Basis)	
			1 (Allowed)	0 (Restricted)
1	1	1 (*2)	Billing for Incoming Call Trunk Arrival Time Abandoned Call	Not Output
1	0	1 (*2)	Billing for Incoming Call	Not Output
0	1	1 (*2)	Not Output	Not Output
0	0	1 (*2)	Not Output	Not Output
1	1	0 (*3)	Not Output	Not Output
1	0	0 (*3)	Not Output	Not Output
0	1	0 (*3)	Not Output	Not Output
0	0	0 (*3)	Not Output	Not Output

\*1: When CS Report is in service, the setting value of CSMDS (CDN70) is enabled.

\*2: Also, when no ARTI/ARTIN data is set or CSMDS (CDN70) bits 0-3 = 0, Billing for Incoming Call is enabled.

\*3: To disable Billing for Incoming Call, set "0" to CSMDS (CDN70) bit 1 and "1" to bit 0 or bits 2-3.

#### CDN: 70 CSMDS (ARTI)

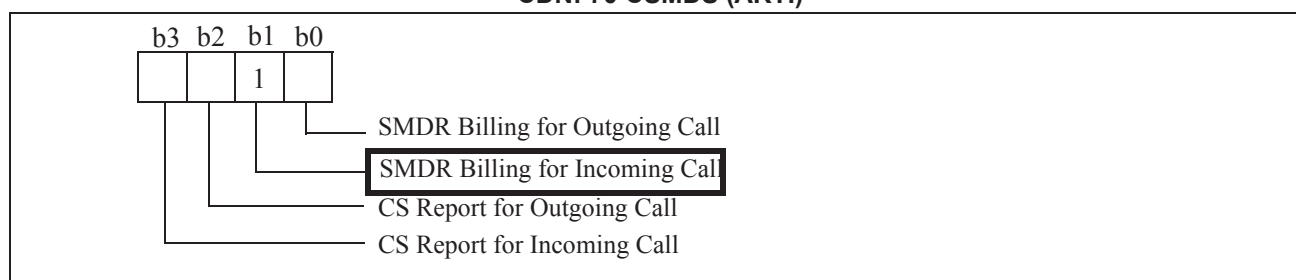

STEP 9: **ASFC** - Assign data "1" to SFI 14 of a Service Feature Restriction Class to all traffics (Trunk Basis). Assign data "1" to SFI 58 of a Service Feature Restriction Class to all traffics of which is to be registered on SMDR (STN to STN Basis).

**Note:** The setting enables all traffics to be billing targets. If an unnecessary SMDR data is output, please discard it at the SMDR terminal.

STEP 10: **ARNP** - For the routes flagged for SMDR in ARTD, list the Route Number and the Outgoing Trunk Access Code or Outgoing Trunk Advance Access Code here. If LCR(S) is used, list the route numbers and the LCR(S) Access Code.



## S-10 Station Message Detail Recording (SMDR)

---

STEP 11: **AMND/AMNDL** - Assign the number of digits the Register is to receive for every dialing Code. List the Toll Number ID Data Code for the system to distinguish the Toll Dialing patterns for SMDR registration. The dialing Code listings are identical for LCR(S). Refer to the AMND descriptions for LCR-3/6-DIGIT [L-5] and TOLL RESTRICTION-3/6-DIGIT [T-7].

**Note:** *Toll/Local data is used when ARTD CDN16 (SMDR2) Bit 1 = 1, where SMDR is output for an Outgoing Toll Calls only.*

### FCCS Programming

This data setting describes only the additional or replacement commands used to activate FCCS Services. When used as an FCCS feature, these commands replace the non-network commands (for example, AAED is replaced by AAEDN). Note that the data setting for FCCS Service varies depending on the node. **Note**

STEP 1: **ALRTN** - Assign this command to connect the Logical Route to the Physical Route.

STEP 2: **ATDF** - Assign time difference data if the time between the nodes and the UCT (Universal Coordinated Time) may not be identical on a FCCS Network. The assigned data (time difference margin [Plus/Minus, Hour, Minute] between each FPC and the UCT) is to be written in Network Data Memory (NDM) of the Network Control Node (NCN).

**Note:** *When using ASYDL or ASYDN to program an FCCS feature, the basic programming of ASYD is required in addition to ASYDL or ASYDN.*

## S-10 Station Message Detail Recording (SMDR)

---

### Programming for Centralized Billing - FCCS (Polling Method)

STEP 1: ASYDL - System Data 1, Index 529, Bits 0 and 1. Set a parity check type (Odd/Even/Non)

Bit 1	Bit 0	Parity Check Type
0	0	Odd Parity (Default)
0	1	Odd Parity
1	0	Even Parity
1	1	Non Parity

System Data 1, Index 576,

Bit 0 = 1 (FCCS Centralized Billing Service (Polling Method) is in service.

Bit 2 = 0/1 (SMDR Interface Type: RS232C/LAN) **Note**

**Note:** Set an appropriate interface type (RS232C/LAN) for SMDR equipment that is installed at Center Node only. This bit is not required for Local Node when no SMDR equipment is installed at the Local Node.

System Data 1, Index 577, Bits 0 - 7. Set FPC as follows.

Node	Data for Index 577
Center Node	00 [Hex]
Local Node	Assign FPC of Center Node in hexadecimal (01-FD [Hex]).

System Data 1, Index 578, Bit 0 and Bit 4. Assign data for SMDR A

Bit 0 = 0/1 (ICS format/IMX format)

Bit 4 = 0/1 (SMDR A with LAN interface is not used/used)

System Data 1, Index 579, Bit 0 and Bit 4. Assign data for SMDR B

Bit 0 = 0/1 (ICS format/IMX format)

Bit 4 = 0/1 (SMDR B with LAN interface is not used/used)

System Data 1, Index 580, Bit 0 and Bit 4. Assign data for SMDR C

Bit 0 = 0/1 (ICS format/IMX format)

Bit 4 = 0/1 (SMDR C with LAN interface is not used/used)

System Data 1, Index 581, Bit 0 and Bit 4. Assign data for SMDR D

Bit 0 = 0/1 (ICS format/IMX format)

Bit 4 = 0/1 (SMDR D with LAN interface is not used/used)

### S-10 Station Message Detail Recording (SMDR)

---

System Data 1, Index 582, Bits 0-3. Assign the number of nodes to be polled in a polling. When default value is used, polling is performed to one node at each polling.

Bit 3	Bit 2	Bit 1	Bit 0	Number of Nodes to be polled
0	0	0	0	1 node
0	0	0	1	1 node
0	0	1	0	2 nodes
0	0	1	1	3 nodes
0	1	0	0	4 nodes
0	1	0	1	5 nodes
0	1	1	0	6 nodes
0	1	1	1	7 nodes
1	0	0	0	8 nodes
1	1	1	1	

System Data 1, Index 583, Bits 0-2. Assign the cycle to send billing data to the node which accommodates the calling station. The billing data is sent from node which accommodates the originating trunk (Outgoing Call SMDR) or the called station (Station-to-Station SMDR).

Bit 2	Bit 1	Bit 0	Cycle to Send
0	0	0	8 seconds
0	0	1	2 seconds
0	1	0	4 seconds
0	1	1	6 seconds
1	0	0	8 seconds
1	0	1	10 seconds
1	1	0	12 seconds
1	1	1	14 seconds

**Note:** *By default, the data is transmitted every 8 seconds.*

## S-10 Station Message Detail Recording (SMDR)

---

System Data 1, Index 585, Bits 0-7. Modify the polling cycle between nodes at the Center Node if required. The default cycle (2 seconds) can be modified in one of the following cases to avoid buffer overflow at Local Node:

- FCCS network consists of many Local Nodes
- Local Node is specified as a Main Node of Centralized Billing - CCIS

Bit 2	Bit 1	Bit 0	Cycle to Send
0	0	0	8 seconds
0	0	1	2 seconds
0	1	0	4 seconds
0	1	1	6 seconds
1	0	0	8 seconds
1	0	1	10 seconds
1	1	0	12 seconds
1	1	1	14 seconds

System Data 1, Index 586, Bits 0-7. Modify the upper limit of polling buffer usage rate (01% - 99%) if required. The default value is 50%. If the usage rate exceeds this value, polling will not be performed.

b7	b6	b5	b4	b3	b2	b1	b0
Tens				Unit			

**Note:** *When the Centralized Billing Office cannot receive any billing information for 20 seconds, billing information created at local offices is not to be sent to the Centralized Billing Office. In this case, when there is no other destination for a local office to output the billing information than the Centralized Billing Office-CCIS, the information will be deleted. As long as this incapability of sending information persists, the transmission status is to be checked in order from the oldest.*

**Note:** *This setting applies to “No.7 Centralized Billing -CCIS”, “Centralized Billing -FCCS”, and “CS Report [for UMG system] [C-149]”.*

System Data 1, Indexes 608-639. Assign FPCs of nodes that are polled by Center Node.

System Data 1, Index 641 Output Number and Route Number designation that is applied for SMDR - ICS format only.

Bit 0 = 0/1 (Station Number/Telephone Number)

Bit 4 = 0/1 (Physical Route Number/Logical Route Number)

**Note:** *If the number of digits of Telephone Number is within 6 digits, the Telephone Number will be output when Bit 0 = 1.*

STEP 2: ASYDN - System Data 1, Index 583 Bit 7. Specify node to which SMDR data should be stored.  
0/1 = (Node accommodating the calling party/Node accommodating the outgoing trunk or the called party)

## S-10 Station Message Detail Recording (SMDR)

---

**Note:** *Be sure to assign Bit 7= 1 when the SMDR terminal is not connected to the Local Node in order to collect the billing information quickly.*